

WORKSHOP CALCULATION & SCIENCE

(NSQF)

(As per Revised Syllabus July 2022)

Industrial Painter



Directorate General of Training

DIRECTORATE GENERAL OF TRAINING
MINISTRY OF SKILL DEVELOPMENT & ENTREPRENEURSHIP
GOVERNMENT OF INDIA



**NATIONAL INSTRUCTIONAL
MEDIA INSTITUTE, CHENNAI**

Post Box No. 3142, CTI Campus, Guindy, Chennai - 600 032

Workshop Calculation & Science
Industrial Painter - 1 Year NSQF
As per Revised Syllabus July 2022

Developed & Published by



National Instructional Media Institute

Post Box No.3142
Guindy, Chennai - 600032
INDIA
Email: chennai-nimi@nic.in
Website: www.nimi.gov.in

Copyright © 2023 National Instructional Media Institute, Chennai

First Edition : February 2023

Copies: 1000

Rs: 85/-

All rights reserved.

No part of this publication can be reproduced or transmitted in any form or by any means, electronic or mechanical, including photocopy, recording or any information storage and retrieval system, without permission in writing from the National Instructional Media Institute, Chennai.

FOREWORD

The Government of India has set an ambitious target of imparting skills to 30 crores people, one out of every four Indians, by 2020 to help them secure jobs as part of the National Skills Development Policy. Industrial Training Institutes (ITIs) play a vital role in this process especially in terms of providing skilled manpower. Keeping this in mind, and for providing the current industry relevant skill training to Trainees, ITI syllabus has been recently updated with the help of comprising various stakeholder's viz. Industries, Entrepreneurs, Academicians and representatives from ITIs.

The National Instructional Media Institute (NIMI), Chennai, has now come up with instructional material to suit the revised curriculum for **Workshop Calculation & Science - Industrial Painter** NSQF (Revised 2022) under CTS will help the trainees to get an international equivalency standard where their skill proficiency and competency will be duly recognized across the globe and this will also increase the scope of recognition of prior learning. NSQF trainees will also get the opportunities to promote life long learning and skill development. I have no doubt that with NSQF the trainers and trainees of ITIs, and all stakeholders will derive maximum benefits from these IMPs and that NIMI's effort will go a long way in improving the quality of Vocational training in the country.

The Executive Director & Staff of NIMI and members of Media Development Committee deserve appreciation for their contribution in bringing out this publication.

Jai Hind

Director General (Training),
Ministry of Skill Development & Entrepreneurship,
Government of India.

New Delhi - 110 001

PREFACE

The National Instructional Media Institute(NIMI) was set up at Chennai, by the Directorate General of Training, Ministry of skill Development and Entrepreneurship, Government of India, with the technical assistance from the Govt of the Federal Republic of Germany with the prime objective of developing and disseminating instructional Material for various trades as per prescribed syllabus and Craftsman Training Programme(CTS) under NSQF levels.

The Instructional materials are developed and produced in the form of Instructional Media Packages (IMPs), consisting of Trade Theory, Trade Practical, Test and Assignment Book, Instructor Guide. The above material will enable to achieve overall improvement in the standard of training in ITIs.

A national multi-skill programme called SKILL INDIA, was launched by the Government of India, through a Gazette Notification from the Ministry of Finance (Dept of Economic Affairs), Govt of India, dated 27th December 2013, with a view to create opportunities, space and scope for the development of talents of Indian Youth, and to develop those sectors under Skill Development.

The emphasis is to skill the Youth in such a manner to enable them to get employment and also improve Entrepreneurship by providing training, support and guidance for all occupation that were of traditional types. The training programme would be in the lines of International level, so that youths of our Country can get employed within the Country or Overseas employment. The **National Skill Qualification Framework (NSQF)**, anchored at the National Skill Development Agency(NSDA), is a Nationally Integrated Education and competency-based framework, to organize all qualifications according to a series of **levels of Knowledge, Skill and Aptitude**. Under NSQF the learner can acquire the Certification for Competency needed at any level through formal, non-formal or informal learning.

The **Workshop Calculation & Science - Industrial Painter NSQF (Revised 2022)** under CTS is one of the book developed by the core group members as per the NSQF syllabus.

The **Workshop Calculation & Science - Industrial Painter NSQF (Revised 2022)** under CTS as per NSQF is the outcome of the collective efforts of experts from Field Institutes of DGT, Champion ITI's for each of the Sectors, and also Media Development Committee (**MDC**) members and Staff of **NIMI**. NIMI wishes that the above material will fulfill to satisfy the long needs of the trainees and instructors and shall help the trainees for their Employability in Vocational Training.

NIMI would like to take this opportunity to convey sincere thanks to all the Members and Media Development Committee (MDC) members.

Chennai - 600 032

EXECUTIVE DIRECTOR

ACKNOWLEDGEMENT

The National Instructional Media Institute (NIMI) sincerely acknowledge with thanks the co-operation and contribution of the following Media Developers to bring this IMP for the course **Workshop Calculation & Science - Industrial Painter** as per NSQF Revised 2022.

MEDIA DEVELOPMENT COMMITTEE MEMBERS

Shri. M. Sangara pandian	-	Training Officer (Retd.) CTI, Govt. of India, Guindy, Chennai - 32.
Shri. G. Sathiamoorthy	-	Jr. Training Officer - SG (Retd.) Govt I.T.I, Trichy, DET - Tamilnadu.

NIMI CO-ORDINATORS

Shri. Nirmalya Nath	-	Deputy General Manager, NIMI, Chennai - 32.
Shri. G. Michael Johny	-	Manager, NIMI, Chennai - 32.

NIMI records its appreciation of the **Data Entry, CAD, DTP Operators** for their excellent and devoted services in the process of development of this IMP.

NIMI also acknowledges with thanks, the efforts rendered by all other staff who have contributed for the development of this book.

INTRODUCTION

The material has been divided into independent learning units, each consisting of a summary of the topic and an assignment part. The summary explains in a clear and easily understandable fashion the essence of the mathematical and scientific principles. This must not be treated as a replacement for the instructor's explanatory information to be imparted to the trainees in the classroom, which certainly will be more elaborate. The book should enable the trainees in grasping the essentials from the elaboration made by the instructor and will help them to solve independently the assignments of the respective chapters. It will also help them to solve the various problems, they may come across on the shop floor while doing their practical exercises.

The assignments are presented through 'Graphics' to ensure communications amongst the trainees. It also assists the trainees to determine the right approach to solve the problems. The required relevant data to solve the problems are provided adjacent to the graphics either by means of symbols or by means of words. The description of the symbols indicated in the problems has its reference in the relevant summaries.

At the end of the exercise wherever necessary assignments, problems are included for further practice.

Time allotment:

Duration of 1 Year : 30 Hrs

Time allotment for each title of exercises has been given below. **Workshop Calculation & Science - Industrial Painter NSQF Revised Syllabus 2022.**

S.No	Title	Exercise No.	Time in Hrs
1	Unit, Fractions	1.1.01 - 1.1.07	4
2	Square root, Ratio and Proportions, Percentage	1.2.08 - 1.2.14	6
3	Material Science	1.3.15 - 1.3.19	8
4	Mass, Weight, Volume and Density	1.4.20	2
5	Mensuration	1.5.21 & 1.5.22	4
6	Levers and Simple machines	1.6.23	2
7	Trigonometry	1.7.24 - 1.7.26	4
		Total	30 Hrs

LEARNING / ASSESSABLE OUTCOME

On completion of this book you shall be able to

- **Demonstrate basic mathematical concept and principles to perform practical operations.**
- **Understand and explain basic science in the field of study.**

CONTENTS

Exercise No.	Title of the Exercise	Page No.
	Unit, Fractions	
1.1.01	Unit, Fractions - Classification of unit system	1
1.1.02	Unit, Fractions - Fundamental and Derived units F.P.S, C.G.S, M.K.S and SI units	2
1.1.03	Unit, Fractions - Measurement units and conversion	3
1.1.04	Unit, Fractions - Factors, HCF, LCM and problems	8
1.1.05	Unit, Fractions - Fractions - Addition, subtraction, multiplication & division	9
1.1.06	Unit, Fractions - Decimal fractions - Addition, subtraction, multiplication & division	12
1.1.07	Unit, Fractions - Solving problems by using calculator	15
	Square root, Ratio and Proportions, Percentage	
1.2.08	Square root, Ratio and Proportions, Percentage - Square and square root	19
1.2.09	Square root, Ratio and Proportions, Percentage - Simple problems using calculator	20
1.2.10	Square root, Ratio and Proportions, Percentage - Applications of pythagoras theorem and related problems	21
1.2.11	Square root, Ratio and Proportions, Percentage - Ratio and proportion	23
1.2.12	Square root, Ratio and Proportions, Percentage - Ratio and proportion - Direct and indirect proportions	25
1.2.13	Square root, Ratio and Proportions, Percentage - Percentage	28
1.2.14	Square root, Ratio and Proportions, Percentage - Changing percentage to decimal and fraction	30
	Material Science	
1.3.15	Material science - Types of metals, types of ferrous and non ferrous metals	31
1.3.16	Material science - Physical and mechanical properties of metals	33
1.3.17	Material science - Introduction of iron and cast iron	36
1.3.18	Material science - Difference between iron & steel, alloy steel and carbon steel	39
1.3.19	Material science - Properties and uses of rubber, timber and insulating materials	41
	Mass, Weight, Volume and Density	
1.4.20	Mass, Weight, Volume and Density - Mass, volume, density, weight and specific gravity	44
	Mensuration	
1.5.21	Mensuration - Area and perimeter of square, rectangle and parallelogram	46
1.5.22	Mensuration - Area and perimeter of triangles	50
	Levers and Simple machines	
1.6.23	Lever & Simple machines - Lever and its types	54
	Trigonometry	
1.7.24	Trigonometry - Measurement of angles	57
1.7.25	Trigonometry - Trigonometrical ratios	59
1.7.26	Trigonometry - Trigonometrical tables	62

SYLLABUS

1 Year

Workshop Calculation & Science - Industrial Painter Revised syllabus July 2022 under CTS

S.No.	Title	Time in Hrs
I	Unit, Fractions 1 Classification of Unit System 2 Fundamental and Derived Units F.P.S, C.G.S, M.K.S and SI Units 3 Measurement Units and Conversion 4 Factors, HCF, LCM and Problems 5 Fractions – Addition, Subtraction, Multiplication & Division 6 Decimal Fractions – Addition, Subtraction, Multiplication & Division 7 Solving Problems by using calculator	4
II	Square root, Ratio and Proportions, Percentage 1 Square and Square root 2 Simple problems using calculator 3 Applications of Pythagoras theorem and related problems 4 Ratio and Proportion 5 Ratio and Proportion - Direct and Indirect proportions 6 Percentage 7 Percentage - Changing percentage to decimal and fraction	6
III	Material Science 1 Types of metal, types of ferrous and non ferrous metals 2 Physical and Mechanical Properties of metals 3 Introduction of iron and cast iron 4 Difference between iron & steel, alloy steel and carbon steel 5 Properties and uses of rubber, timber and insulating materials	8
IV	Mass, Weight, Volume, and Density 1 Mass, volume, density, weight and specific gravity	2
V	Mensuration 1 Area and perimeter of square, rectangle and parallelogram 2 Area and perimeter of triangles	4
VI	Levers and Simple Machines 1 Levers & Simple Machines - Lever and its types	2
VII	Trigonometry 1 Measurement of angles 2 Trigonometrical ratios 3 Trigonometrical tables	4
	Total	30

Unit, Fractions - Classification of unit system

Necessity

All physical quantities are to be measured in terms of standard quantities.

Unit

A unit is defined as a standard or fixed quantity of one kind used to measure other quantities of the same kind.

Classification

Fundamental units and derived units are the two classifications.

Fundamental units

Units of basic quantities of length, mass and time.

Derived units

Units which are derived from basic units and bear a constant relationship with the fundamental units. E.g. area, volume, pressure, force etc.

Systems of units

- F.P.S system is the British system in which the basic units of length, mass and time are foot, pound and second respectively.
- C.G.S system is the metric system in which the basic units of length, mass and time are centimeter, gram and seconds respectively.
- M.K.S system is another metric system in which the basic units of length, mass and time are metre, kilogram and second respectively.
- S.I. units are referred to as Systems International units which is again of metric and the basic units, their names and symbols are as follows.

Fundamental units and derived units are the two classifications of units.

Length, mass and time are the fundamental units in all the systems (i.e) F.P.S, C.G.S, M.K.S and S.I. systems.

Example

Length: What is the length of copper wire in the roll, if the roll of copper wire weighs 8kg, the dia of wire is 0.9cm and the density is 8.9 gm/cm³?

Solution

mass of copper wire in the roll = 8kg (or) 8000grams

Dia of copper wire in the roll = 0.9cm

Density of copper wire = 8.9 gm/cm³

Area of cross section of copper wire

$$= \frac{\pi d^2}{4} = \frac{\pi \times (0.9^2)}{4} = 0.636 \text{cm}^2$$

Volume of copper wire

$$= \frac{\text{Mass of copper wire}}{\text{Density of copper wire}} = \frac{8000 \text{grams}}{8.9 \text{ gm/cm}^3} = 898.88 \text{cm}^3$$

Length of copper wire

$$= \frac{\text{Volume of copper wire}}{\text{Area of cross section of copper wire}} = \frac{898.88 \text{cm}^3}{0.636 \text{cm}^2} = 1413.33 \text{ cm}$$

Length of copper wire = 1413cm.

Time: The S.I. unit of time, the second, is another base units of S.I., it is defined as the time interval occupied by a number of cycles of radiation from the calcium atom. The second is the same quantity in the S.I. in the British and in the U.S. systems of units.

Fundamental units of F.P.S, C.G.S, M.K.S and S.I

S.No.	Basic quantity	British units		Metric units				International units	
		F.P.S	Symbol	C.G.S	Symbol	M.K.S	Symbol	S.I Units	Symbol
1	Length	Foot	ft	Centimetre	cm	Metre	m	Metre	m
2	Mass	Pound	lb	Gram	g	Kilogram	kg	Kilogram	Kg
3	Time	Second	s	Second	s	Second	s	Second	s
4	Current	Ampere	A	Ampere	A	Ampere	A	Ampere	A
5	Temperature	Fahrenheit	°F	Centigrade	°C	Centigrade	°C	Kelvin	K
6	Light intensity	Candela	Cd	Candela	Cd	Candela	Cd	Candela	Cd

Unit, Fractions - Fundamental and Derived units F.P.S, C.G.S, M.K.S and SI units

Derived units of F.P.S, C.G.S, M.K.S and SI system

S.No	Physical quantity	British units		Metric units				International units	
		FPS	Symbol	CGS	Symbol	MKS	Symbol	SIUnits	Symbol
1	Area	Square foot	ft ²	Square centimetre	cm ²	Square metre	m ²	Square metre	m ²
2	Volume	Cubic foot	ft ³	Cubic centimetre	cm ³	Cubic metre	m ³	Cubic metre	m ³
3	Density	Pound per cubic foot	lb/ft ³	Gram per cubic centimetre	g/cm ³	Kilogram per cubic metre	kg/m ³	Kilogram per cubic metre	Kg/m ³
4	Speed	Foot per second	ft/s	Centimetre per second	cm/sec	Metre per second	m/sec	Metre per second	m/sec
5	Velocity (linear)	Foot per second	ft/s	Centimetre per second	cm/sec	Metre per second	m/sec	Metre per second	m/sec
6	Acceleration	Foot per square second	ft/s ²	Centimetre per square second	cm/sec ²	Metre per square second	m/sec ²	Metre per square second	m/sec ²
7	Retardation	Foot per square Second	ft/s ²	Centimetre per square second	cm/sec ²	Metre per square second	m/sec ²	Metre square second	m/sec ²
8	Angular velocity	Degree per second	Deg/sec	Radian per second	rad/sec	Radian per second	rad/sec	Radian per second	rad/sec
9	Mass	Pound (slug)	lb	Gram	g	Kilogram	kg	Kilogram	kg
10	Weight	Pound	lb	Gram	g	Kilogram weight	kg	Newton	N
11	Force	Pounds	lbf	dyne	dyn	Kilogram force	kgf	Newton	N(kgm/sec ²)
12	Power	Foot pound per second	ft.lb/sec	Gram.centimetre/sec	g.cm/sec	kilogram metre per second	kg.m/sec	-	-
		Horse power	hp	Erg per second		watt	W	watt	W(J/sec)
13	Pressure, Stress	Pound per square inch	lb/in ²	Gram per square centimetre	g/cm ²	Kilogram per square metre	kg/m ²	Newton per square metre	N/m ²
14	Energy, Work	Foot.pound	ft.lb	Gram centimetre	g.cm	Kilogram metre	kg.m	joule	J(Nm)
15	Heat	British thermal unit	BTU	calorie	Cal	joule	J	joule	J(Nm)
16	Torque	Pound force foot	lbf.ft	Newton millimetre	N mm	Kilogram metre	kg.m	Newton metre	Nm
17	Temperature	Degree Fahrenheit	°F	Degree Centigrade	°C	Kelvin	K	Kelvin	K

Unit, Fractions - Measurement units and conversion

Units and abbreviations

Quantity	Units	Abbreviation of unit
Calorific value	kilojoules per kilogram	kJ/kg
Specific fuel consumption	kilogram per hour per newton	kg/hr/N
Length	millimetre, metre, kilometre	mm, m, km
Mass	kilogram, gram	kg, g
Time	seconds, minutes, hours	s, min, h
Speed	centimetre per second, metre per second kilometre per hour, miles per hour	cm/s, m/s km/h, mph
Acceleration	metre-per-square second	m/s ²
Force	newtons, kilonewtons	N, kN
Moment	newton-metres	Nm
Work	joules	J
Power	horsepower, watts, kilowatts	Hp, W, kW
Pressure	newton per square metre kilonewton per square metre	N/m ² kN/m ²
Angle	radian	rad
Angular speed	radians per second radians-per-square second revolutions per minute revolutions per second	rad/s rad/s ² Rpm rev/s

Decimal multiples and parts of unit

Decimal power	Value	Prefixes	Symbol	Stands for
10 ¹²	1000000000000	tera	T	billion times
10 ⁹	1000000000	giga	G	thousand millintimes
10 ⁶	1000000	mega	M	million times
10 ³	1000	kilo	K	thousand times
10 ²	100	hecto	h	hundred times
10 ¹	10	deca	da	ten times
10 ⁻¹	0.1	deci	d	tenth
10 ⁻²	0.01	centi	c	hundredth
10 ⁻³	0.001	milli	m	thousandth
10 ⁻⁶	0.000001	micro	μ	millionth
10 ⁻⁹	0.000000001	nano	n	thousand millionth
10 ⁻¹²	0.000000000001	pico	p	billionth

SI units and the British units:

Quantity	SI unit → British unit	British unit → SI unit
Length	1 m = 3.281 ft 1 km = 0.621 mile	1 ft = 0.3048 m 1 mile = 1.609 km
Speed	1 m/s = 3.281 ft/s 1 km/h = 0.621 mph	1 ft/s = 0.305 m/s 1 mph = 1.61 km/h
Acceleration	1 m/s ² = 3.281 ft/s ²	1 ft/s ² = 0.305 m/s ²
Mass	1 kg = 2.205 lb	1 lb = 0.454 kg
Force	1 N = 0.225 lbf 1 MN	1 lbf = 4.448 N 1 million newtons
Torque	1 Nm = 0.738 lbf ft	1 lbf ft = 1.355 Nm
Pressure	1 N/m ² = 0.000145 lbf/in ² 1 Pa = 1 N/m ² 1 bar = 14.5038 lbf/in ²	1 lbf/in ² = 6.896 kN/m ² 1 lbf/in ² = 6.895 kN/m ²
Energy, work	1 J = 0.738 ft lbf 1 J = 0.239 calorie 1 kJ = 0.948 BTU (1 therm = 100 000 BTU) 1 kJ = 0.526 CHU	1 ft lbf = 1.355 J 1 calorie = 4.186 J 1 BTU = 1.055 kJ 1 CHU = 1.9 kJ
Power	1 kW = 1.34 hp	1 hp = 0.7457 kW
Fuel consumption	1 km/L = 2.82 mile/gallon	1 mpg = 0.354 km/L
Specific fuel consumption	1 kg/kWh = 1.65 lb/bhp h 1 litre/kWh = 1.575 pt/bhp h	1 lb/bhp h = 0.606 kg/kWh 1 pt/bhp h = 0.631 litre/kWh
Calorific value	1 kJ/kg = 0.43 BTU/lb 1 kJ/kg = 0.239 CHU/lb	1 BTU/lb = 2.326 kJ/kg 1 CHU/lb = 4.188 kJ/kg

Prefixes for decimal multiples and submultiples

Use	
1 Megapascal	= 1 MPa = 1000000 Pa
1 Kilowatt	= 1 kW = 1000 W
1 Hectolitre	= 1 hL = 100 L
Decanewton	= 1 daN = 10 N
Decimetre	= 1 dm = 0.1 m
1 Centimetre	= 1 cm = 0.01 m
1 Millimetre	= 1 mm = 0.001 m
1 Micrometre	= 1 μ m = 0.000001 m

Conversion factors

1 inch	= 25.4 mm
1 mm	= 0.03937 inch
1 metre	= 39.37 inch
1 micron	= 0.00003937"
1 kilometre	= 0.621 miles
1 pound	= 453.6 g
1 kg	= 2.205 lbs
1 metric ton	= 0.98 ton

Units of physical quantities

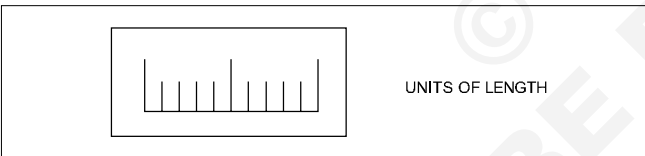

Units of length

Micron	1 μ	= 0.001 mm
Millimetre	1 mm	= 1000 μ
Centimetre	1 cm	= 10 mm
Decimetre	1 dm	= 10 cm
Metre	1 m	= 10 dm
Kilometre	1 km	= 1000 m
Inch	1"	= 25.4 mm
Foot	1'	= 0.305 m
Yard	1 Yd	= 0.914 m
Nautical mile	1 NM	= 1852 m
Geographical mile	1	= 1855.4 m

Units of area

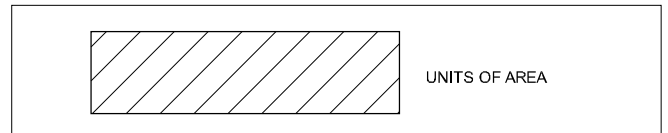

Square millimetre	1 mm ²	
Square centimetre	1 cm ²	= 100 mm ²
Square decimetre	1 dm ²	= 100 cm ²
Square metre	1 m ²	= 100 dm ²
Are	1 a	= 100 m ²
Hectare	1 ha	= 100 a
Square kilometre	1 km ²	= 100 ha
Square inch	1 sq.in	= 6.45 cm ²
Square foot	1 sq.ft	= 0.093 m ²
Square yard	1 sq.yd	= 0.84 m ²
Square metre	1 m ²	= 10.76 ft ²
Acre	1	= 40.5 a

1 Acre = 100 cent
 1 Cent = 436 Sq. ft.
 1 Ground = 2400 Sq.ft.

1 Hectare	= 2.47 acres
1 acre	= 0.4047 Hectare
1 Hectare	= 10000 sq. metre

Units of weight

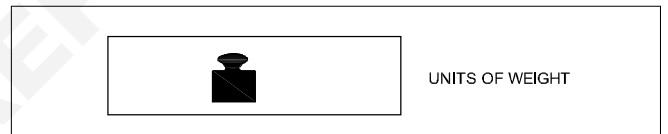

Milligram - force	1 mgf	
Gram-force	1 gf	= 1000 mgf
Kilogram-force	1 kgf	= 1000 gf
Tonne	1 t	= 1000 kgf
Ounce	1	= 28.35 gf
Pound	1 lbs	= 0.454 kgf
Long ton	1	= 1016 kgf
Short ton	1	= 907 kgf

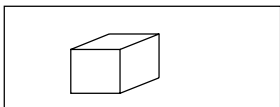

UNITS OF VOLUME AND CAPACITY

Units of volume and capacity

Cubic millimetre	1 mm ³	
Cubic centimetre	1 cm ³	= 1000 mm ³
Cubic decimetre	1 dm ³	= 1000 cm ³
Cubic metre	1 m ³	= 1000 dm ³
Litre	1 l	= 1 dm ³
Hectolitre	1 hl	= 100 l
Cubic inch	1 cu. in	= 16.387 cm ³
Cubic foot	1 cu. ft	= 28317 cm ³
Gallon (British)	1 gal	= 4.54 l
1 cubic metre	1 m ³	= 1000 litres
1000 Cu.cm	1000 cm ³	= 1 litre
1 cubic foot	1 ft ³	= 6.25 Gallon
1 litre	1lt	= 0.22 Gallon

Circular unit

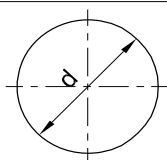

CIRCULAR OF UNIT

Radian

Relationship between Radian and Degree

$$1 \text{ Radian} = \frac{180^\circ}{\pi}$$

$$180^\circ = \pi \text{ Radian};$$

$$1 \text{ Degree} = \frac{\pi}{180} \text{ Radian}$$

Work

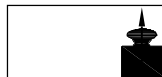

WORK

Kilogram-force	1 kgfm	= 9.80665 J
Metre	1 kgfm	= 9.80665 Ws
Joule	1 J	= 1 Nm
Watt-second	1 Ws	= 0.102 kgfm
Kilowatt hour	1 kWh	= 3.6 x 10 ⁶ J
		= 859.8456 kcal _{IT}
I.T.Kilocalorie	1 kcal _{IT}	= 426.kgfm

Power



POWER

Kilogram-force metre/second

1 kgfm/s	= 9.80665 W
Kilowatt	1 kW = 1000 W = 1000 J/s
	= 102 kgfm/s (approx.)
Metric horse power	1 HP = 75 kgfm/s
	= 0.736 kW
1 Calorie	= 4.187J
I.T.Kilocalorie/hour	= 1 kcal _{IT/h} = 1.163 W

Pressure

Pascal	1 Pa	= 1 N/m ²	1 atm	= 101325 Pa
Bar	1 bar = 10N/cm ²	= 100000 Pa–Torr	1 torr	= $\frac{101325}{760} \approx 133.32 \text{ pa}$
Atmosphere	1 atm	= 1 kgf/cm ²	1 kgf/cm ²	= 735.6 mm of mercury

TEMPERATURE

Scale	Freezing point	Boiling point
Centigrade (°C)	0°C	100°C
Fahrenheit (°F)	32°F	212°F
Kelvin (K)	273K	373K
Reaumur (°R)	0°R	80°R

TEMPERATURE



$$\frac{^\circ\text{R}}{80} = \frac{^\circ\text{C}}{100} = \frac{\text{K} - 273}{100} = \frac{^\circ\text{F} - 32}{180}$$

FORCE

Force	In C.G.S. System : Force (Dyne) = Mass (gm) X Acceleration (cm/sec ²)
	In F.P.S. System : Force (Poundal) = Mass (lb) X Acceleration (ft./sec ²)
	In M.K.S System : Force (Newton) = Mass (Kg) x Acceleration (mtr./sec ²)
1 Dyne	= 1 gm x 1 cm/sec ²
1 Poundal	= 1 lb x 1 ft/sec ²
1 Newton	= 1 kg x 1 mtr/sec ² = 10 ⁵ dynes
1gm weight	= 981 Dynes
1 lb weight	= 32 Poundals
1 kg weight	= 9.81 Newtons

ELECTRICAL QUANTITIES

V	Electric potential	V	Volt	V(W/A)
E	Electromotive force	V	Volt	V(W/A)
I	Electric current	A	Ampere	A
R	Electric resistance	Ω	Ohm	Ω (V/A)
e	Specific resistance	Ω m	Ohm metre	Vm/A
G	Conductance	Ω ⁻¹	Siemens	S

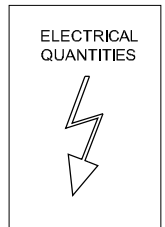

Assignment - Answer the following question.

- Convert 320 kilometres into miles _____
- Convert 16 tons into kilograms _____
- Convert 40 inches into centimetres _____
- Convert 8 metres into feet _____
- Convert 2.5 gallons into litres _____
- Convert 5 litres into gallons _____
- 120°C = _____ °F.
- Expand the abbreviations of the following
 - N/m²
 - RPM
- Convert the following S.I. units as required.
 - Length
 - 3.4 m = _____ mm
 - 10.2 km = _____ mile
 - Mass
 - 650 g = _____ kg
 - 120 mg = _____ g
 - Force
 - 1.2 N = _____ kg
 - 25 kg = _____ N
 - Work, energy, amount of heat
 - 120 KJ = _____ J
 - 300 wh = _____ kwh
 - Power
 - 0.2 kW = _____ W
 - 350 W = _____ kW
 - Convert as required.
 - 5 N = _____ KN

Unit, Fractions - Factors, HCF, LCM and problems

Prime Numbers and whole Numbers

Factor

A factor is a small number which divides exactly into a bigger number.e.g.

To find the factors of 24, 72, 100 numbers

$$24 = 2 \times 2 \times 2 \times 3$$

$$72 = 2 \times 2 \times 2 \times 3 \times 3$$

$$100 = 2 \times 2 \times 5 \times 5$$

The numbers 2,3,5 are called factors.

Definition of a prime factor

Prime factor is a number which divides a prime number into factors.e.g.

$$57 = 3 \times 19$$

The numbers 3 and 19 are prime factors.

They are called as such, since 3 & 19 also belong to prime number category.

Definition of H.C.F

The Highest Common Factor

The H.C.F of a given group of numbers is the highest number which will exactly divide all the numbers of that group.e.g.

To find the H.C.F of the numbers 24, 72, 100

$$24 = 2 \times 2 \times 2 \times 3$$

$$72 = 2 \times 2 \times 2 \times 3 \times 3$$

$$100 = 2 \times 2 \times 5 \times 5$$

The factors common to all the three numbers are

$$2 \times 2 = 4. \text{ So HCF} = 4.$$

Definition of L.C.M

Lowest common multiple

The lowest common multiple of a group of numbers is the smallest number that will contain each number of the given group without a remainder.e.g.

- Factorise the following numbers

$$7,17,20,66,128$$

7,17 - These two belong to Prime numbers. Hence no factor except unity and itself.

$$\begin{array}{r|l} 2 & 20 \\ 2 & 10 \\ & 5 \end{array}$$

Factors of 20 = $2 \times 2 \times 5$

$$\begin{array}{r|l} 2 & 66 \\ 3 & 33 \\ & 11 \end{array}$$

Factors of 66 = $2 \times 3 \times 11$

$$\begin{array}{r|l} 2 & 128 \\ 2 & 64 \\ 2 & 32 \\ 2 & 16 \\ 2 & 8 \\ 2 & 4 \\ & 2 \end{array}$$

Factors of 128 = $2 \times 2 \times 2 \times 2 \times 2 \times 2 \times 2$

- Select prime numbers from 3 to 29
3,5,7,11,13,17,19,23,29
- Find the HCF of the following group of numbers HCF of 78, 128, 196

$$\begin{array}{r|l} 2 & 78 \\ 3 & 39 \\ & 13 \end{array}$$

$$78 = 2 \times 3 \times 13$$

$$\begin{array}{r|l} 2 & 128 \\ 2 & 64 \\ 2 & 32 \\ 2 & 16 \\ 2 & 8 \\ 2 & 4 \\ & 2 \end{array}$$

$$128 = 2 \times 2 \times 2 \times 2 \times 2 \times 2 \times 2$$

$$\begin{array}{r|l} 2 & 196 \\ 2 & 98 \\ & 49 \end{array}$$

$$196 = 2 \times 2 \times 49$$

$$\text{HCF} = 2$$

- Find LCM of 84,92,76

$$\text{LCM} = \begin{array}{r|l} 2 & 84, 92, 76 \\ 2 & 42, 46, 38 \\ 3 & 21, 23, 19 \\ & 7, 23, 19 \end{array}$$

$$\text{LCM} = 2 \times 2 \times 3 \times 7 \times 23 \times 19 = 36708$$

- To find out the LCM of 36, 108, 60

$$\begin{array}{r|l} 2 & 36, 108, 60 \\ 2 & 18, 54, 30 \\ 3 & 9, 27, 15 \\ 3 & 3, 9, 5 \\ & 1, 3, 5 \end{array}$$

LCM of the number

$$36, 108, 60 = 2 \times 2 \times 3 \times 3 \times 3 \times 5 = 540$$

The necessity of finding LCM and HCF arises in subtraction and addition of fractions.

Unit, Fractions - Fractions - Addition, subtraction, multiplication & division

Description

A minimal quantity that is not a whole number. For e.g. .

$\frac{1}{5}$ a vulgar fraction consists of a numerator and denominator.

Numerator/Denominator

The number above the line in a vulgar fraction showing how many of the parts indicated by the denominator are taken is the numerator. The total number of parts into which the whole quantity is divided and written below the line in a vulgar fraction is the denominator. e.g.

$$\frac{1}{4}, \frac{3}{4}, \frac{7}{12}$$

1,3,7 - numerators 4,12 - denominators

Fraction: Concept

Every number can be represented as a fraction.e.g.

$1\frac{1}{4} = \frac{5}{4}$, A full number can be represented as an apparent fraction.e.g. (Fig 1)

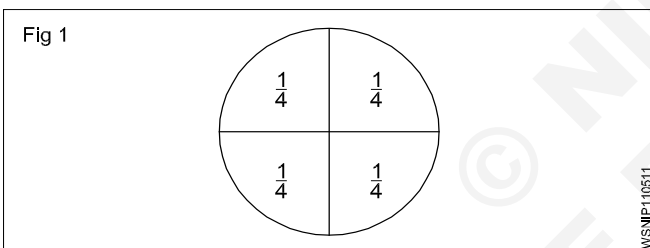

Fraction: Value

The value of a fraction remains the same if the numerator and denominator of the fraction are multiplied or divided by the same number.(Fig 2)

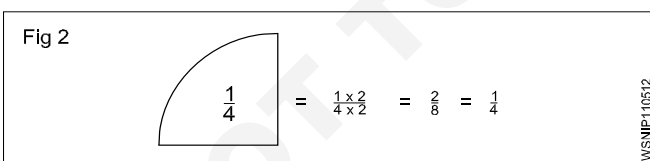

Multiplication

When fractions are to be multiplied, multiply all the numerators to get the numerator of the product and multiply all the denominators to form the denominator of the product. (Fig 3)

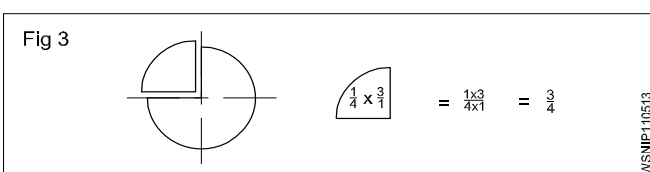

Division

When a fraction is divided by another fraction the dividend is multiplied by the reciprocal of the divisor. (Fig 4)

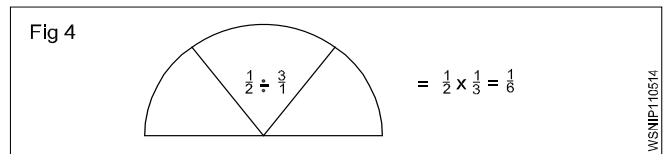

Addition and Subtraction

The denominators of the fractions should be the same when adding or subtracting the fractions. Unequal denominators must first be formed into a common denominator. It is the lowest common denominator and it is equal to the product of the most common prime numbers of the denominators of the fractions in question.(Fig 5)

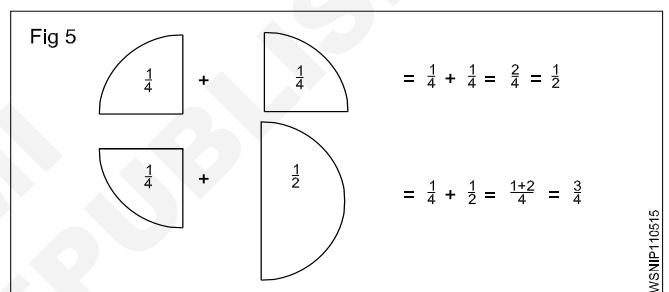

Examples

- Multiply $\frac{3}{4}$ by $\frac{2}{3}$,

$$\frac{3}{4} \times \frac{2}{3} = \frac{6}{12} = \frac{1}{2}$$

- Divide $\frac{3}{8}$ by $\frac{3}{4}$,

$$\frac{3}{8} \div \frac{3}{4} = \frac{3}{8} \times \frac{4}{3} = \frac{1}{2}$$

- Add $\frac{3}{4}$ and $\frac{2}{3}$,

$$\frac{3}{4} + \frac{2}{3} = \frac{9}{12} + \frac{8}{12} = \frac{17}{12} = 1\frac{5}{12}$$

- sub $\frac{7}{16}$ from $\frac{17}{32}$

$$\frac{17}{32} - \frac{7}{16} = \frac{17}{32} - \frac{14}{32} = \frac{(17 - 14)}{32} = \frac{3}{32}$$

Types of fractions

- Proper fractions are less than unity. Improper fractions have their numerators greater than the denominators.
- A mixed number has a full number and a fraction.

Addition of fraction

$$\text{Add } \frac{1}{2} + \frac{1}{8} + \frac{5}{12}$$

To add these fractions we have to find out L.C.M of denominators 2,8,12.

Find L.C.M of 2,8,12

Step 1 L.C.M

2	2,8,12
2	1,4,6
	1,2,3

Factors are 2,2,2,3

Hence L.C.M = $2 \times 2 \times 2 \times 3 = 24$

Step 2

$$\begin{aligned} \frac{1}{2} + \frac{1}{8} + \frac{5}{12} &= \frac{12}{24} + \frac{3}{24} + \frac{10}{24} \\ &= \frac{12+3+10}{24} = \frac{25}{24} = 1\frac{1}{24} \end{aligned}$$

Subtraction of fraction

$$\text{subtract } 9\frac{15}{32} \text{ from } 17\frac{9}{16} \text{ or } (17\frac{9}{16} - 9\frac{15}{32})$$

Step 1: Subtract whole number first $17 - 9 = 8$

Step 2: L.C.M of 16,32 = 32

Since number 16 divides the number 32

$$\text{Subtracting fractions} = \frac{3}{32}$$

Adding with whole number from Step 1

$$\text{we get } 8 + \frac{3}{32} = 8\frac{3}{32}$$

Common fractions

Problems with plus and minus sign

Example

$$\text{solve } 3\frac{3}{4} + 6\frac{7}{8} - 4\frac{5}{16} - \frac{9}{32}$$

Rule to be followed

- 1 Add all whole numbers
- 2 add all + Numbers
- 3 Add all - Numbers
- 4 Find L.C.M of all denominators

Solution

Step 1: Add whole numbers = $3 + 6 - 4 = 5$

$$\text{Step 2: Add fractions} = \frac{3}{4} + \frac{7}{8} - \frac{5}{16} - \frac{9}{32}$$

L.C.M of 4,8,16,32 is 32

$$\begin{aligned} & \frac{24 + 28 - 10 - 9}{32} \\ &= \frac{52 - 19}{32} \\ &= \frac{33}{32} = 1\frac{1}{32} \end{aligned}$$

Step 3: Adding again with the whole number

$$\text{we get } 5 + 1\frac{3}{32} = 6\frac{3}{32}$$

Examples

Common fractions

- Multiply

$$\text{a } \frac{3}{8} \text{ by } \frac{4}{7} = \frac{3}{8} \times \frac{4}{7} = \frac{3}{14} \quad \text{b } \frac{2}{3} \times \frac{3}{4} \times \frac{5}{8} = \frac{5}{16}$$

- Division

$$\text{a } \frac{5}{16} \div \frac{5}{32} = \frac{5}{16} \times \frac{32}{5} = 2$$

$$\text{b } 4\frac{2}{3} \div 3\frac{1}{7} = \frac{14}{3} \div \frac{22}{7} = \frac{14}{3} \times \frac{7}{22} = \frac{49}{33} = 1\frac{16}{33}$$

- Addition

$$\frac{1}{2} + \frac{1}{4} + \frac{1}{8}$$

L.C.M = 2,4,8 = 8

$$\frac{1}{2} + \frac{1}{4} + \frac{1}{8} = \frac{4+2+1}{8} = \frac{7}{8}$$

- Subtraction

$$5\frac{1}{4} - 3\frac{3}{4} = 5 - 3 + \frac{1}{4} - \frac{3}{4}$$

$$= 2 + \frac{1}{4} - \frac{3}{4} = 2 - \frac{2}{4}$$

$$= \frac{9}{4} - \frac{3}{4} = \frac{9-3}{4}$$

$$= \frac{6}{4} = \frac{3}{2} = 1\frac{1}{2}$$

Assignment

1 Convert the following into improper fractions.

a $1\frac{2}{7} = \underline{\hspace{2cm}}$

b $4\frac{3}{5} = \underline{\hspace{2cm}}$

c $3\frac{3}{5} = \underline{\hspace{2cm}}$

2 Convert the following into mixed numbers.

a $\frac{12}{11} = \underline{\hspace{2cm}}$

b $\frac{36}{14} = \underline{\hspace{2cm}}$

c $\frac{18}{10} = \underline{\hspace{2cm}}$

3 Place the missing numbers.

a $\frac{11}{13} = \frac{x}{91}$ _____

b $\frac{3}{5} = \frac{42}{x}$ _____

c $\frac{9}{14} = \frac{x}{98}$ _____

4 Simplify.

a $\frac{45}{60} = \underline{\hspace{2cm}}$

b $\frac{8}{12} = \underline{\hspace{2cm}}$

5 Multiply.

a $5 \times \frac{2}{3} = \underline{\hspace{2cm}}$

b $\frac{3}{4} \times 2 = \underline{\hspace{2cm}}$

c $\frac{3}{4} \times \frac{5}{6} = \underline{\hspace{2cm}}$

6 Divide

a $\frac{1}{4} \div \frac{3}{4} = \underline{\hspace{2cm}}$

b $6 \div \frac{3}{4} = \underline{\hspace{2cm}}$

c $\frac{3}{4} \div \frac{2}{7} = \underline{\hspace{2cm}}$

7 Place the missing numbers.

a $\frac{2}{3} = \frac{1}{12} \times \underline{\hspace{2cm}}$

b $\frac{14}{24} = \frac{1}{12} \times \underline{\hspace{2cm}}$

c $\frac{7}{8} = \frac{1}{12} \times \underline{\hspace{2cm}}$

8 Add the followings:

a $\frac{3}{4} + \frac{7}{12} = \underline{\hspace{2cm}}$

b $\frac{7}{8} + \frac{3}{4} = \underline{\hspace{2cm}}$

9 Subtract

a $\frac{4}{5} - \frac{2}{5} = \underline{\hspace{2cm}}$

b $\frac{5}{6} - \frac{3}{4} = \underline{\hspace{2cm}}$

10 Simplify

a $2\frac{6}{7} - \frac{3}{8} - \frac{1}{3} - 1\frac{1}{16} = \underline{\hspace{2cm}}$

b $2\frac{2}{7} - \frac{5}{6} + 8 = \underline{\hspace{2cm}}$

11 Express as improper fractions

a $5\frac{3}{4}$

b $3\frac{5}{64}$

c $1\frac{5}{12}$

Unit, Fractions - Decimal fractions - Addition, subtraction, multiplication & division

Description

Decimal fraction is a fraction whose denominator is 10 or powers of 10 or multiples of 10 (i.e.) 10, 100, 1000, 10000 etc. Meaning of a decimal number:-

12.3256 means

$$(1 \times 10) + (2 \times 1) + \frac{3}{10} + \frac{2}{100} + \frac{5}{1000} + \frac{6}{10000}$$

Representation

The denominator is omitted. A decimal point is placed at different positions of the number corresponding to the magnitude of the denominator

Ex. $\frac{5}{10} = 0.5, \frac{35}{100} = 0.35, \frac{127}{10000} = 0.0127, \frac{3648}{1000} = 3.648$

Addition and subtraction

Arrange the decimal fractions in a vertical order, placing the decimal point of each fraction to be added or subtracted, in succession one below the other, so that all the decimal points are arranged in a straight line. Add or subtract as you would do for a whole number and place the decimal point in the answer below the column of decimal points.

Decimal fractions less than 1 are written with a zero before the decimal point. Example: $45/100 = 0.45$ (and not simply .45)

Add $0.375 + 3.686$

$$\begin{array}{r} 0.375 \\ 3.686 \\ \hline 4.061 \end{array}$$

Subtract 18.72 from 22.61

$$\begin{array}{r} 22.61 \\ 18.72 \\ \hline 3.89 \end{array}$$

Multiplication

Ignore the decimal points and multiply as whole numbers. Find the total number of digits to the right of the decimal point. Insert the decimal point in the answer such that the number of digits to the right of the decimal point equals to the sum of the digits found to the right of the decimal points in the problem.

Multiply 2.5 by 1.25

= $25 \times 125 = 3125$. The sum of the figures to the right of decimal point is 3. Hence the answer is 3.125.

Division

Move the decimal point of the divisor to the right to make it a full number. Move the decimal point in the dividend to

the same number of places, adding zeroes if necessary. Then divide.

Divide 0.75 by 0.25

$$0.25 \overline{)0.75}$$

$$\frac{0.75}{0.25} \times \frac{100}{100} = \frac{75}{25}$$

$$25 \overline{)75} = 3$$

Move the decimal point in the multiplicand to the right to one place if the multiplier is 10, and to two places if the multiplier is 100 and so on. When dividing by 10 move the decimal point one place to the left, and, if it is by 100, move them point by two places and so on.

Example

Allowance allowing 3 mm for cutting off each pin, how many pins can be made from a 900 mm long bar and how much material will be left out?

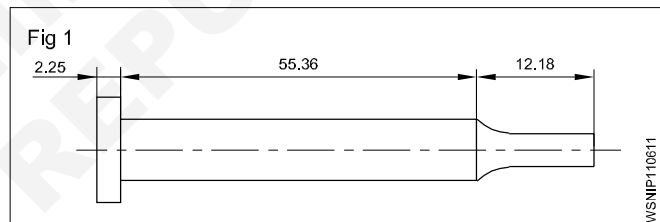

Total Length of pin = $2.25 + 55.36 + 12.18$
= 69.79 mm

Cutting allowance = 3 mm

Total Length = length of pin + cutting allowance
= $69.79 \text{ mm} + 3 \text{ mm}$
= 72.79 mm

Length of the bar = 900 mm

No. of pins to be cut = $\frac{900}{72.79} = 12.394$
= 12 pins

Left out material = Total length - length of pin + cutting allowance
= $900 - 12 \times 69.79 + 12 \times 3$
= $900 - 837.48 + 36$
= $900 - 873.48$

Left out length = 26.52 mm

Conversion of Decimals into fractions and vice-versa

- Convert decimal into fractions

Example

Convert 0.375 to a fraction

Now place 1 under the decimal point followed by as many zeros as there are numbers

$$0.375 = \frac{375}{1000} = \frac{15}{40} = \frac{3}{8}$$

$$0.375 = \frac{3}{8}$$

- Convert fraction into decimal

Example

- Convert $\frac{9}{16}$ to a decimal

Proceed to divide $\frac{9}{16}$ in the normal way of division but put zeros (as required) after the number 9 (Numerator)

$$\begin{array}{r} 0.5625 \\ 16 \overline{)90000} \\ \underline{80} \\ 100 \\ \underline{96} \\ 40 \\ \underline{32} \\ 80 \\ \underline{80} \\ 0 \end{array}$$

$$\frac{9}{16} = 0.5625$$

Recurring decimals

While converting from fraction to decimals, some fractions can be divided exactly into a decimal. In some fractions the quotient will not stop. It will continue and keep recurring. These are called recurring decimals.

Examples

- convert $\frac{1}{3}, \frac{2}{3}, \frac{1}{7}$

a $\frac{1}{3} = \frac{10000}{3} = 0.3333$ – Recurring

b $\frac{2}{3} = \frac{20000}{3} = 0.666$ – Recurring

c $\left(\frac{1}{7} = \frac{10000}{7} = 0.142857142 \right)$ – Recurring

Method of writing approximations in decimals

$$\begin{array}{lll} 1.73556 & = & 1.7356 \quad \text{Correct to 4 decimal places} \\ 5.7343 & = & 5.734 \quad \text{Correct to 3 decimal places} \\ 0.9345 & = & 0.94 \quad \text{Correct to 2 decimal places} \end{array}$$

Multiplication and division by 10, 100, 1000

Multiplying decimals by 10

A decimal fraction can be multiplied by 10, 100, 1000 and so on by moving the decimal point to the right by as many places as there are zeros in the multiplier.

- $4.645 \times 10 = 46.45$ (one place)
- $4.645 \times 100 = 464.5$ (two places)
- $4.645 \times 1000 = 4645$ (three places)

Dividing decimals by 10

A decimal fraction can be divided by 10, 100, 1000 and so on, by moving the decimal point to the left by as many places as required in the divisor by putting zeros

Examples

- $3.732 \div 10 = 0.3732$ (one place)
- $3.732 \div 100 = 0.03732$ (two places)
- $3.732 \div 1000 = 0.003732$ (three places)

Examples

- Rewrite the following number as a fraction

453.273

$$= (4 \times 100) + (5 \times 10) + (3 \times 1) + \frac{2}{10} + \frac{7}{100} + \frac{3}{1000}$$

$$= 453 \frac{273}{1000}$$

- Write the representation of decimal places in the given number 0.386

- 3 - 1st decimal place
- 8 - 2nd decimal place
- 6 - 3rd decimal place

- Write approximations in the following decimals to 3 places.

a $6.9453 \longrightarrow 6.945$

b $8.7456 \longrightarrow 8.746$

- Convert fraction to decimal

$$\frac{21}{24} = \frac{7}{8} = 0.875$$

- Convert decimal to fraction

$$0.0625 = \frac{625}{10000} = \frac{5}{80} = \frac{1}{16}$$

Assignment

- 1 Write down the following decimal numbers in the expanded form.
- a 514.726
b 902.524
- 2 Write the following decimal numbers from the expansion.
- a $500 + 70 + 5 + \frac{3}{10} + \frac{2}{100} + \frac{9}{1000}$
b $200 + 9 + \frac{1}{10} + \frac{3}{100} + \frac{5}{1000}$
- 3 Convert the following decimals into fractions in the simplest form.
- a 0.72
b 5.45
c 3.64
d 2.05
- 4 Convert the following fraction into decimals
- a $\frac{3}{5}$
b $\frac{10}{4}$
c $24 \frac{54}{1000}$
d $\frac{12}{25}$
e $\frac{8}{25}$
f $1 \frac{3}{25}$
- 5 Addition of decimals
- a $4.56 + 32.075 + 256.6245 + 15.0358$
b $462.492 + 725.526 + 309.345 + 626.602$
- 6 Subtract the following decimals
- a $612.5200 - 9.6479$
b $573.9246 - 215.6000$
- 7 Add and subtract the following
- a $56.725 + 48.258 - 32.564$
b $16.45 + 124.56 + 62.7 - 3.243$
- 8 Multiply the following
- a By 10, 100, 1000
i 3.754×10
ii 8.964×100
iii 2.3786×1000
iv 0.005×1000
- b By whole numbers
i 8.4×7
ii 56.72×8
- c By another decimal figure (use calculator)
i 15.64×7.68
ii 2.642×1.562
- 9 Divide the following
- a $\frac{62.5}{25}$
b $\frac{64.56}{10}$
c $\frac{0.42}{100}$
d $\frac{48.356}{1000}$
- 10 Division
- a $\frac{16.8}{1.2}$
b $\frac{1.54}{1.1}$
- 11 Change the fraction into a decimal
- i $1 \frac{5}{8}$
ii $\frac{12}{25}$
- 12 Find the value
 $20.5 \times 40 \div 10.25 + 18.50$

Unit, Fractions - Solving problems by using calculator

A pocket calculator allows to spend less time in doing tedious calculations. A simple pocket calculator enables to do the arithmetical calculations of addition, subtraction, multiplication and division, while a scientific type of calculator can be used for scientific and technical calculations also.

No special training is required to use a calculator. But it is suggested that a careful study of the operation manual of the type of the calculator is essential to become familiar with its capabilities. A calculator does not think and do. It is left to the operator to understand the problem, interpret the information and key it into the calculator correctly.

Constructional Details (Fig 1)

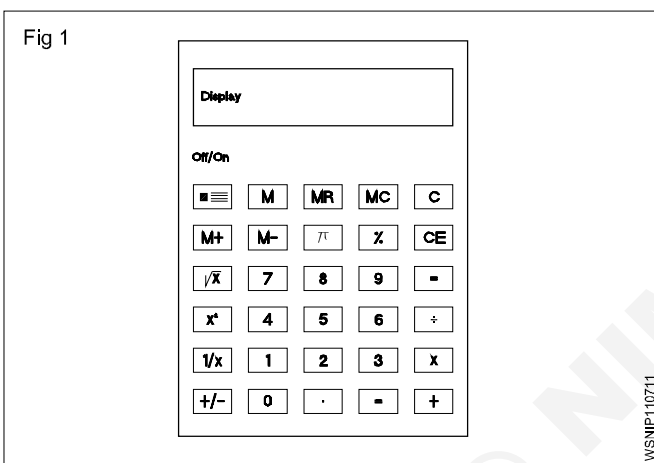

The key board is divided into five clear and easily recognizable areas and the display.

• Data entry keys

The entry keys are from 0to 9

and a key for the decimal point . .

• Clearing keys

These keys have the letter 'C'

C CLR Clear totally

CE Clear entry only

CM , MC Clear memory

- + Addition key
- Subtraction key
- x Multiplication key
- ÷ Division key
- = Equals key to display the result

• Function keys

- π Pi key
- √x Square root key
- % Percentage key
- +/- Sign change key
- x² Square key
- 1/x Reciprocal key

• Memory keys

- M Store the display number
- M+ The displayed value is added to the memory
- M- The displayed value is subtracted from the memory
- MR RCL The stored value is recalled on to the display

Further functional keys included in Scientific calculators are as shown in Fig 2.

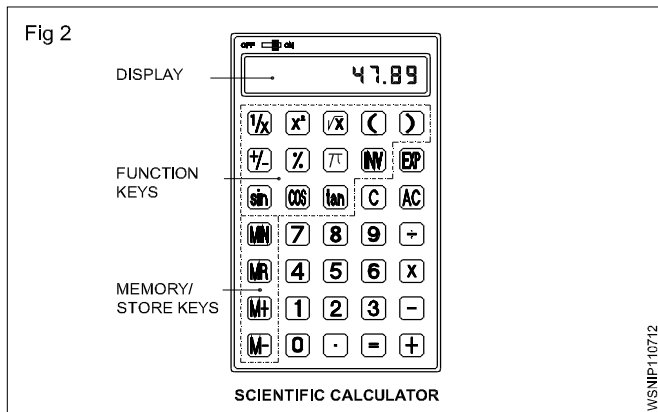

\sin \cos \tan $($ $)$ For trigonometric functions and for brackets

Exp Exponent key

INV Some of the keys have coloured lettering above or below them. To use a function in coloured lettering, press INV key. INV will appear on the display. Then press the key that the coloured lettering identifies. INV will disappear from the display.

\log , INV 10^x to obtain the logarithm of the displayed number and the antilogarithm of the displayed value.

INV R-P to convert displayed rectangular coordinates into polar coordinates.

INV P-R to convert displayed polar coordinates into rectangular coordinates.

• **The display**

The display shows the input data, interim results and answers to the calculations.

The arrangement of the areas can differ from one make to another. Keying in of the numbers is done via. an internationally agreed upon set of ten keys in the order that the numbers are written.

Rules and Examples:

- **Addition:** Example $18.2 + 5.7$

Sequence	Input	Display
Input of the 1st term of the sum	18.2	18.2
Press + key	$+$	18.2
Input 2nd term of the sum. the first term goes into the register	5.7	5.7
Press the = key	$=$	23.9

- **Subtraction:** Example $128.8 - 92.9$

Sequence	Input	Display
Enter the subtrahend	128.8	128.8
Press - key	$-$	128.8
Enter the minuend. The subtrahend goes into the register	92.9	92.9
Press the = key	$=$	35.9

- **Multiplication:** Example 0.47×2.47

Sequence	Input	Display
Enter multiplicand	0.47	0.47
Press x key	\times	0.47
Enter multiplier, multiplicand goes to register	2.47	2.47
Press = key	$=$	1.1609

- **Division:** Example $18.5/2.5$

Sequence	Input	Display
Enter the dividend	18.5	18.5
Press ÷ Key	\div	18.5
Enter the divisor goes to the register	2.5	2.5
Press = key	$=$	7.4

- **Multiplication & Division:**
Example : $2.5 \times 7.2 / 4.8 \times 1.25$

Sequence	Input	Display
Enter 2.5	2 . 5	2.5
Press x key	x	2.5
Enter 7.2	7 . 2	7.2
Press ÷ key	÷	18
Enter Open bracket	(
Enter 4.8	4 . 8	4.8
Press x key	x	4.8
Enter 1.25	1 . 2 5	1.25
Enter Close bracket)	6
Press = key	=	3.0

- Store in memory Example $(2+6) (4+3)$

Sequence	Input	Display
Workout for the first bracket	2	2
	+	2
	6	6
	=	8
Store the first result in	STO , M	8
x	or M+	
Workout for the 2nd bracket	4	4
	+	4
	3	3
	=	7
Press x key	x	7
Recall memory	RCL or MR	8
Press = key	=	56

- **Percentage:** Example 12% of 1500

Sequence	Input	Display
Enter 1500	1 5 0 0	1500
Press x key	x	1500
Enter 12	1 2	12
Press INV %	INV %	12
Press = key	=	180

- **Square root:** Example $\sqrt{2} + \sqrt{3 \times 5}$

Sequence	Input	Display
Enter 2	2	2
Press \sqrt{a} key	\sqrt{a}	1.414
Press + key	+	1.414
Press bracket key	(1.414
Enter 3	3	3
Press \sqrt{a} key	\sqrt{a}	1.732
Press x key	x	1.732
Enter 5	5	5
Press \sqrt{a} key	\sqrt{a}	2.236
Press bracket close key)	3.873
Press = key	=	5.2871969
	2 \sqrt{a} + (3 \sqrt{a} x 5 \sqrt{a}) =	5.2871969

$$\sqrt{2} + \sqrt{3 \times 5} = 5.287$$

- **Common logarithm:** Example $\log 1.23$

Sequence	Input	Display
	1 . 2 3 log =	0.0899051

- **Power:** Example $123 + 30^2$

Sequence	Input	Display
	1 2 3 + 3 0 INV X ² =	1023

- Before starting the calculations be sure to press the 'ON' key and confirm that '0' is shown on the display.
- Do not touch the inside portion of the calculator. Avoid hard knocks and unduly hard pressing of the keys.
- Maintain and use the calculator in between the two extreme temperatures of 0° and 40° C.

- Never use volatile fluids such as lacquer, thinner, benzene while cleaning the unit.
- Take special care not to damage the unit by bending or dropping.
- Do not carry the calculator in your hip pocket.

Assignment

1 Using calculator solve the following

- $625 + 3467 + 20 + 341 + 6278 =$ _____
- $367.4 + 805 + 0.7 + 7.86 + 13.49 =$ _____
- $0.043 + 1.065 + 13.0 + 34.76 + 42.1 =$ _____
- $47160 + 1368.4 + 0.1 + 1.6901 + 134.267 =$ _____

2 Using calculator simplify the following

- $24367 - 4385 =$ _____
- $9.643 - 0.7983 =$ _____
- $4382.01 - 381.3401 =$ _____
- $693.42 - 0.0254 =$ _____

3 Using calculator find the values of the following

- $23 \times 87 =$ _____
- $1376 \times 0.81 =$ _____
- $678 \times 243 =$ _____
- $0.75 \times 0.24 =$ _____

4 Using calculator solve the following

- $22434 \div 3 =$ _____
- $4131 \div 243 =$ _____
- $469890 \div 230 =$ _____
- $3.026 \div 0.89 =$ _____

5 Solve the following

- $\frac{1170 \times 537.5}{13 \times 215} =$ _____
- $\frac{28.2 \times 18 \times 3500}{1000 \times 3 \times 0.8} =$ _____

6 Solve the following

- $\frac{(634 + 128) \times (384 - 0.52)}{8 \times 0.3} =$ _____

$$b \frac{(389 - 12.2) \times (842 - 0.05 - 2.6)}{(3.89 - 0.021) \times (28.1 + 17.04)} =$$

7

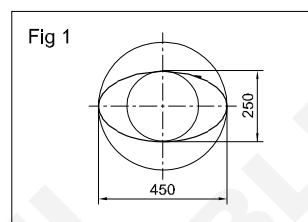

$$2a = 450 \text{ mm (major axis)}$$

$$2b = 250 \text{ mm (minor axis)}$$

Perimeter of the ellipse

$$A = \text{_____ metre}^2$$

$$\text{Hint } A = \pi \times a \times b \text{ unit}^2$$

8

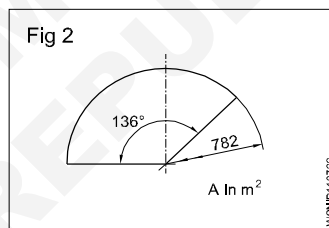

$$\phi = 782 \text{ mm}$$

$$\alpha = 136^\circ$$

Area of the sector

$$A = \text{_____}$$

$$\text{Hint } A = \frac{\pi \times d^2}{4} \times \frac{\alpha}{360^\circ}$$

9

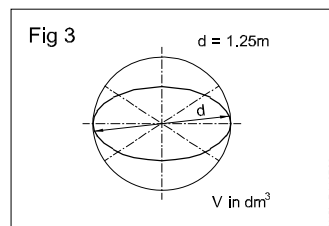

$$d = 1.25 \text{ metre}$$

$$V = \text{_____ dm}^3$$

Volume of sphere

$$\text{Hint } V = \frac{4}{3} \pi r^3$$

10

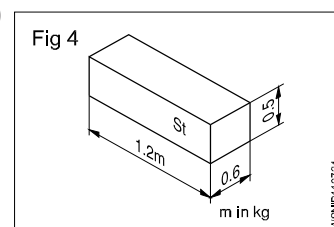

$$L = 1.2 \text{ metres}$$

$$B = 0.6 \text{ metre}$$

$$H = 0.5 \text{ metre}$$

' ρ ' (rho) density of steel

$$= 7.85 \text{ kg/dm}^3$$

$$m = \text{_____ kg}$$

$$\text{(mass 'm' = V x } \rho \text{)}$$

Square root, Ratio and Proportions, Percentage - Square and square root

- a basic number
- 2 exponent

√ radial sign indicating the square root.

√a² square root of 'a' square

a² radicand

Square number

The square of a number is the number multiplied by itself.

Basic number x basic number = Square number

a x a = a²

4 x 4 = 4² = 16

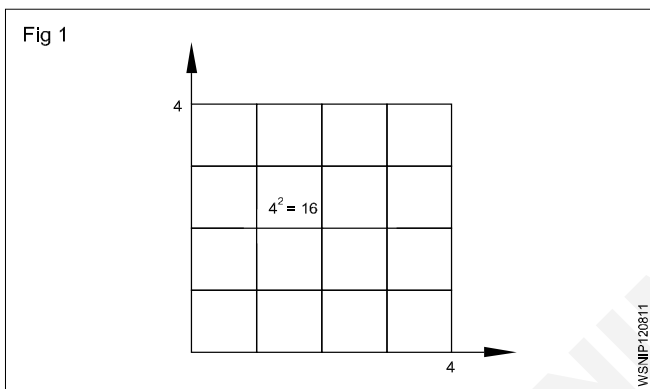

Splitting up

A square area can be split up into sub-areas. The largest square of 36 is made up of a large square 16, a small square 4 and two rectangles 8 each.

Large square 4 x 4 = 16 a²

Two rectangles 2 x 4 x 2 = 16 2ab

Small square 2 x 2 = 4 b²

Sum of sub-areas = 36 = a² + 2ab + b²

√36 = √a² + 2ab + b²

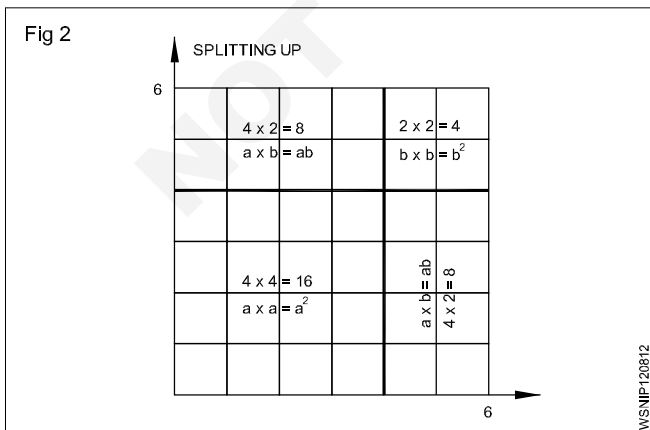

Result: In order to find the square root, we split up the square numbers.

Extracting the square root procedure

- Starting from the decimal point form groups of two figures towards right and left. Indicate by a prime symbol. √4624.00
- Find the root of the first group, calculate the difference, bring down the next group.
- Multiply the root by 2 and divide the partial radicand.
- Enter the number thus calculated in the divisor for the multiplication.

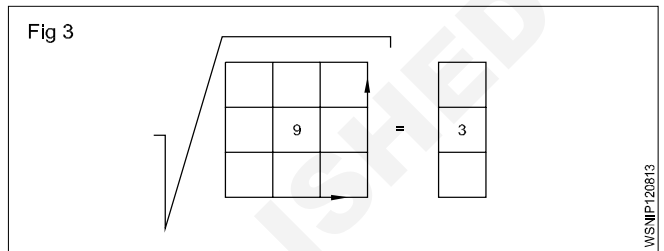

If there is a remainder, repeat the procedure.

$$\begin{array}{r}
 68 \\
 6 \overline{) 46,24} \\
 \underline{36} \\
 1024 \\
 \underline{1024} \\
 0
 \end{array}$$

√4624 = 68

Basic number x basic number = Square

√Square number = basic number

Example

The cross-section of a rivet is 3.46 cm². Calculate the diameter of the hole.

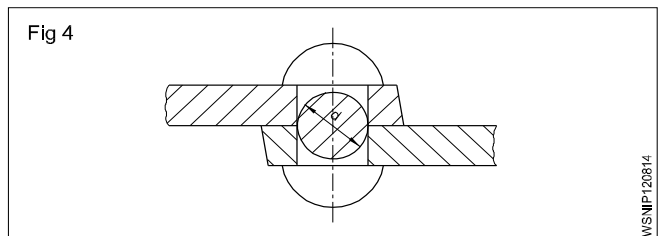

Rivet cross-section is the hole cross-section.

To find 'd',

Given that Area = 3.46 cm²

Area = 0.785 x d² (formula)

3.46 cm² = d² x 0.785

$$d^2 = \frac{3.46 \text{ cm}^2}{0.785}$$

$$d = \sqrt{\frac{3.46}{0.785}} \text{ cm}$$

d = 2.1 cm (or) 21mm

Square root, Ratio and Proportions, Percentage - Simple problems using calculator

1 a $\sqrt{2916} = \underline{\hspace{2cm}}$

b $\sqrt{45796} = \underline{\hspace{2cm}}$

c $\sqrt{8.2944} = \underline{\hspace{2cm}}$

d $\sqrt{63.845} = \underline{\hspace{2cm}}$

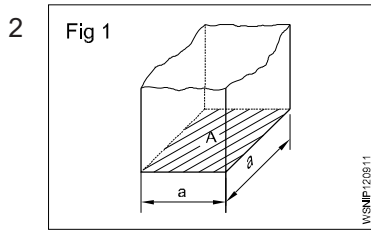

A = 2025 mm²
a = mm

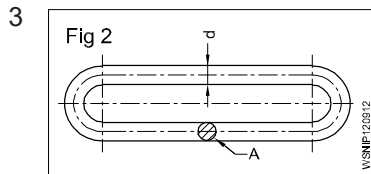

A = 176.715 mm²
d = mm

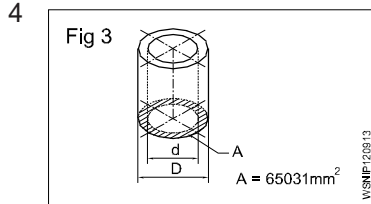

A = 65031 mm²
d = 140 mm
D = mm

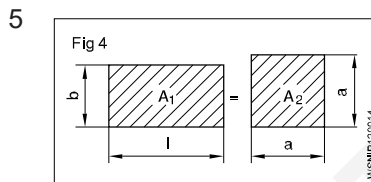

l = 58 cm
b = 45 cm
A₁ = A₂
a = cm

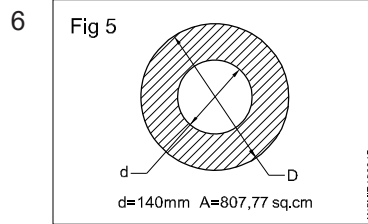

A = 807.77 cm²
d = 140 mm
D = mm

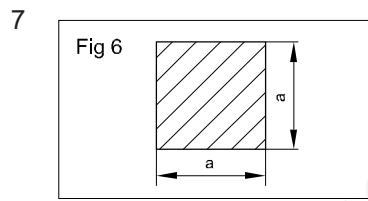

a x a = 543169 mm²
a = mm

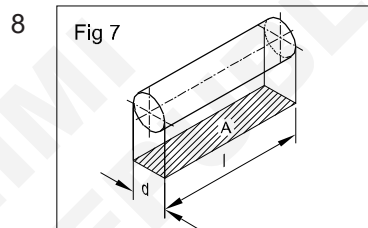

d : l = 1:1.5
A = 73.5 mm²
d = mm

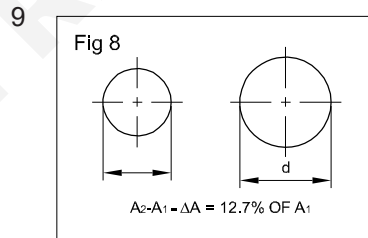

increase in area
A = 12.7%
A = 360 mm²
d = mm
(d = diameter after the increase in area)

Square root, Ratio and Proportions, Percentage - Applications of pythagoras theorem and related problems

Applications of Pythagoras Theorem

Some of the applications of the Pythagoras theorem are; (Fig 1)

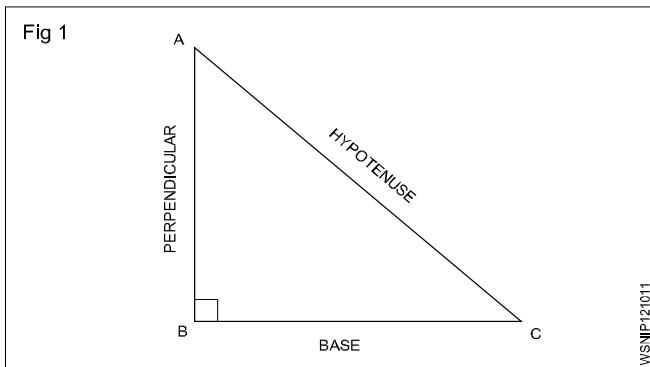

- 1 The Pythagoras theorem is commonly used to find the lengths of sides of a right-angled triangle.
- 2 It is used to find the length of the diagonal of a square.
- 3 Pythagoras theorem is used in trigonometry to find the trigonometric ratios like sin, cos, tan, cosec, sec and cot.
- 4 Pythagoras theorem is used in security cameras for face recognition.
- 5 Architects use the technique of the Pythagoras theorem for engineering and construction fields.
- 6 The Pythagoras theorem is applied in surveying the mountains.
- 7 It is also used in navigation to find the shortest route.
- 8 By using the Pythagoras theorem, we can derive the formula for base, perpendicular and hypotenuse.
- 9 Painters use ladders to paint on high buildings with the help of the Pythagoras theorem.
- 10 Pythagoras theorem is used to calculate the steepness of slopes of hills or mountains.
- 11 The converse of the Pythagoras theorem is used to check whether a triangle is a right triangle or not.

Application of pythagoras theorem in real life

Pythagoras theorem states that

"In a right-angled triangle, the square of the hypotenuse side is equal to the sum of squares of the other two sides".

- 1 The sides of this triangle have been named Perpendicular, Base and Hypotenuse.
- 2 The hypotenuse is the longest side, as it is opposite to the angle 90° .

- 3 The sides of a right triangle (say AB, BC and CA) which have positive integer values, when squared, are put into an equation, also called a Pythagorean triplet.
- 4 To calculate the length of staircase required to reach a window
- 5 To find the length of the longest item can be kept in your room.
- 6 To find the steepness of the hills or mountains.
- 7 To find the original height of a tree broken due to heavy rain and lying on itself
- 8 To determine heights and measurements in the construction sites.

Examples

- 1 What is the side AC if AB = 15 cm, BC = 25 cm.

$$\begin{aligned} AC^2 &= AB^2 + BC^2 \\ &= 15^2 + 25^2 \\ &= 225 + 625 = 850 \end{aligned}$$

$$AC = \sqrt{850} = 29.155 \text{ cm}$$

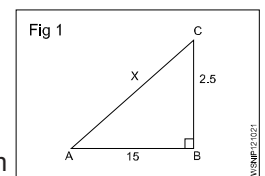

- 2 What is the side BC if AB = 10 cm, AC = 30 cm.

$$\begin{aligned} AC^2 &= AB^2 + BC^2 \\ 30^2 &= 10^2 + BC^2 \\ 900 &= 100 + BC^2 \\ BC^2 &= 900 - 100 = 800 \end{aligned}$$

$$BC = 28.284 \text{ cm}$$

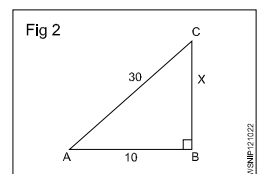

- 3 What is the side AB if BC = 20 cm, AC = 35 cm.

$$\begin{aligned} AC^2 &= AB^2 + BC^2 \\ 35^2 &= AB^2 + 20^2 \\ 1225 &= AB^2 + 400 \\ AB^2 &= 1225 - 400 = 825 \\ AB &= 28.72 \text{ cm} \end{aligned}$$

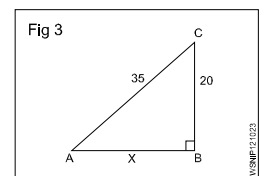

- 4 What is the value of side BC if AB = 8 cm, AC = 24 cm.

$$\begin{aligned} AC^2 &= AB^2 + BC^2 \\ 24^2 &= 8^2 + BC^2 \\ 576 &= 64 + BC^2 \\ BC^2 &= 576 - 64 = 512 \\ BC &= \sqrt{512} = 22.63 \text{ cm} \end{aligned}$$

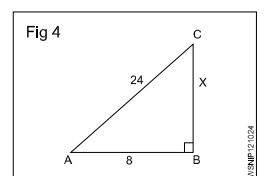

- 5 What is the value side AC if AB = 6.45 cm, BC = 8.52 cm.

$$\begin{aligned} AC^2 &= AB^2 + BC^2 \\ AC^2 &= 6.45^2 + 8.52^2 \\ AC^2 &= 41.60 + 72.59 \\ &= 114.19 \end{aligned}$$

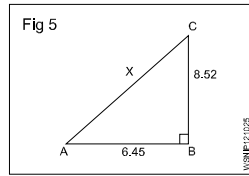

$$AC = \sqrt{114.19} = 10.69 \text{ cm}$$

- 6 What is the value of side AB if BC = 3.26 cm, AC = 8.24 cm.

$$\begin{aligned} AC^2 &= AB^2 + BC^2 \\ 8.24^2 &= AB^2 + 3.26^2 \\ 67.9 &= AB^2 + 10.63 \\ AB^2 &= 67.9 - 10.63 \\ &= 57.27 \end{aligned}$$

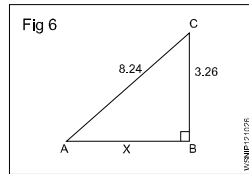

$$AB = \sqrt{57.27} = 7.57 \text{ cm}$$

- 7 What is the value of side AB if AC = 12.5 cm, BC = 8.5 cm.

$$\begin{aligned} AC^2 &= AB^2 + BC^2 \\ 12.5^2 &= AB^2 + 8.5^2 \\ 156.25 &= AB^2 + 72.25 \\ AB^2 &= 156.25 - 72.25 \\ &= 84 \\ AB &= \sqrt{84} = 9.17 \text{ cm} \end{aligned}$$

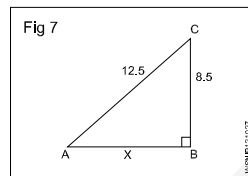

- 8 A ladder of 12.5 metre long is placed with upper end against a wall. The lower end being 7.5 metres from the wall. What height is the upper end above the ground.

$$\begin{aligned} AC^2 &= AB^2 + BC^2 \\ BC^2 &= AC^2 - AB^2 \\ BC^2 &= x^2 \\ AC^2 &= AB^2 + BC^2 \\ 12.5^2 &= x^2 + 7.5^2 \end{aligned}$$

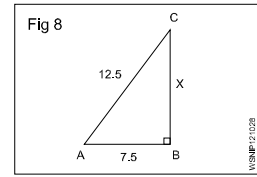

$$\begin{aligned} x^2 &= (12.5)^2 - (7.5)^2 \\ &= (12.5 + 7.5)(12.5 - 7.5)^2 \\ &= 20 \times 5 \\ &= \sqrt{100} = 10 \\ x &= 10 \text{ m} \end{aligned}$$

- 9 What is the value of AB.

$$\begin{aligned} AC^2 &= AB^2 + BC^2 \\ AB^2 &= AC^2 - BC^2 \\ AB^2 &= x^2 \\ AC^2 &= AB^2 + BC^2 \\ 10^2 &= x^2 + 6^2 \\ x^2 &= 10^2 - 6^2 \\ &= 100 - 36 = 64 \\ x &= \sqrt{64} \\ &= 8 \\ AB &= 8 \end{aligned}$$

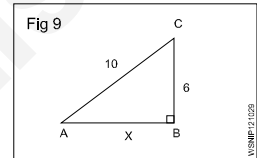

Assignment

- 1 What is the value of side AB, in a right angled triangle of side AC = 10 cm and BC = 5 cm.
- 2 What is the value of side AC, in a right angled triangle of side AB = 6.5 cm and BC = 4.5 cm.
- 3 What is the value of side BC, in a right angled triangle of side AC = 14.5 cm and AB = 10.5 cm.
- 4 What is the value of side AC, in a right angled triangle of side AB = 7 cm and BC = 5 cm.
- 5 What is the value of side BC, in a right angled triangle of side AC = 13.25 cm and AB = 8.75 cm.

Square root, Ratio and Proportions, Percentage - Ratio and proportion

Ratio

Introduction

It is the relation between two quantities of the same kind and is expressed as a fraction.

Expression

a, b two quantities of the same kind. $\frac{a}{b}$ or a:b or a ÷ b or

a in b is the ratio.

Ratio is always reduced to the lowest terms.

Example

$$7:14 = \frac{7}{14} = \frac{1}{2} = 1:2$$

Proportion

It is the equality between the ratios, a : b is a ratio and c : d is another ratio. Both ratios are equal. Then

$$a : b :: c : d \text{ or } \frac{a}{b} = \frac{c}{d}$$

Example

$$250 : 2000 :: 1 : 8$$

Proportion fundamentals

If $\frac{a}{b} = \frac{c}{d}$ then

- $ad = bc$

- $\frac{a}{c} = \frac{b}{d}$

- $\frac{b}{a} = \frac{d}{c}$

- $\frac{a+b}{b} = \frac{c+d}{c}$ and $\frac{a+b}{a} = \frac{c+d}{c}$

- $\frac{a-b}{b} = \frac{c-d}{d}$

- $\frac{a+b}{b+d} = \frac{a}{c} = \frac{c}{d}$

$$3:4::6:8 \text{ or } \frac{3}{4} = \frac{6}{8}$$

- $3 \times 8 = 6 \times 4$

- $\frac{3}{6} = \frac{4}{8}$

- $\frac{4}{3} = \frac{8}{6}$

- $\frac{3+4}{4} = \frac{6+8}{8}$

- $\frac{3-4}{4} = \frac{6-8}{8}$

- $\frac{3+6}{4+8} = \frac{9}{12} = \frac{3}{4}$

**Ratio - relation of two quantities of the same kind.
Proportion - equality between two ratios.**

Example

- A steel plate of 800 x 1400 mm is to be drawn to a scale of 1:20. What will be the lengths in the Fig 1.

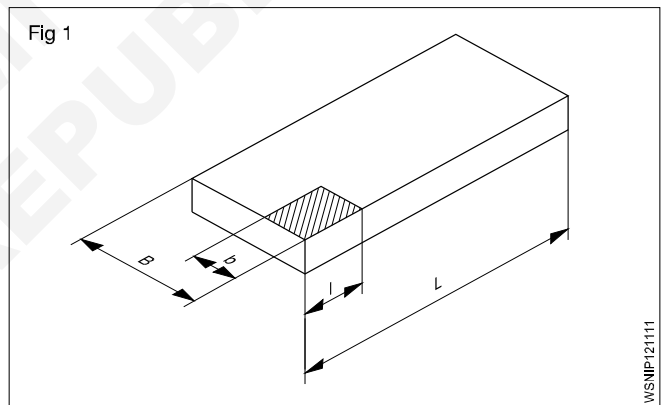

The reduction ratio is $\frac{1}{20}$.

B is reduced from 800 to $800 \times \frac{1}{20} = 40$ mm.

L is reduced from 1400 to $1400 \times \frac{1}{20} = 70$ mm.

- Find the number of teeth of the larger gear in the gear transmission shown in the Fig 2.

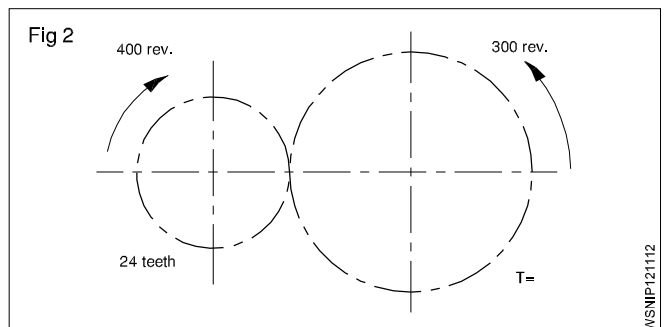

Speed ratio = 400 : 300

Teeth ratio = 24:T

$$\frac{400}{300} = \frac{T}{24}$$

$$\therefore T = \frac{24 \times 400}{300} = 32 \text{ Teeth}$$

Find the ratio of A:B:C

If A:B= 2:3 and B:C=4:5

$$A:B = 2:3$$

$$B:C = 4:5$$

$$A:B = 8 : 12 \text{ (Ratio 2:3 multiply by 4)}$$

$$B:C = 12:15 \text{ (Ratio 4:5 multiply by 3)}$$

$$\therefore A:B:C = 8:12:15$$

Assignment

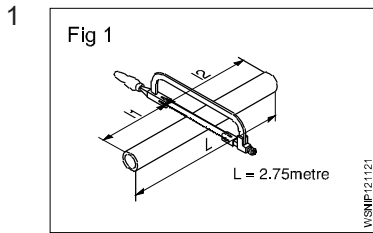

$$l_1 : l_2 = 2:3$$

$$L = 2.75 \text{ metres}$$

$$l_1 = \text{_____ metres}$$

$$l_2 = \text{_____ metres}$$

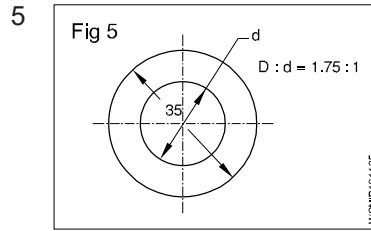

$$D : d = 1.75 : 1$$

$$D = 35 \text{ mm}$$

$$d = \text{_____ mm}$$

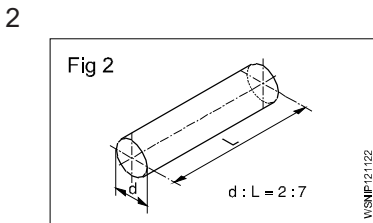

$$d : L \text{ of shaft} = 2:7$$

$$d = 40 \text{ mm}$$

$$L = \text{_____ mm}$$

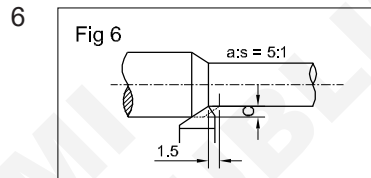

$$a : s = 5 : 1$$

$$s = 1.5 \text{ mm}$$

$$a = \text{_____ mm}$$

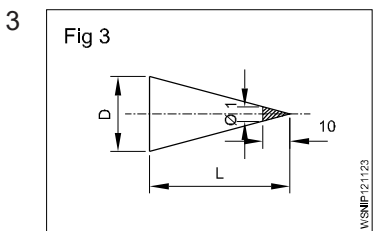

$$D : L = 1:10$$

$$L = 150 \text{ mm}$$

$$D = \text{_____ mm}$$

7 A:B=9:12

B:C=8:10

Then A:B:C= _____

8 A:B=5:6

B:C=3:4

Then A:B:C= _____

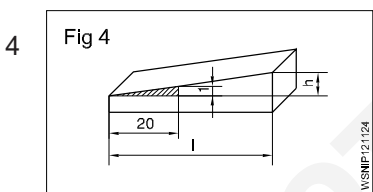

$$\frac{\Delta h}{l} = \frac{1}{20}$$

$$l = 140 \text{ mm}$$

$$\Delta h = \text{_____ mm}$$

9 A:55=9:11

$$A = \text{_____}$$

10 15:9.3=40:x

$$x = \text{_____}$$

Square root, Ratio and Proportions, Percentage - Ratio and Proportions - Direct and indirect proportions

Proportion

Description

It is the equality between the ratios, a:b is a ratio and c:d is another ratio. Both ratios are equal. Then

$a : b :: c : d$ or e.g. $250 : 2000 :: 1 : 8$

Rule of three

A three step calculation

statement

single

multiple.

Direct proportion

The more in one the more in the other - An increase in one denomination produces an increase in the other. (Fig 1)

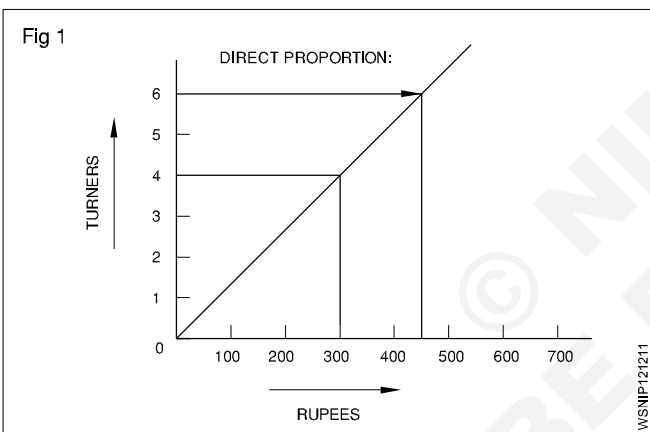

Examples

- 4 turners earn 300 Rupees. How much will 6 Turners earn?

Statement

4 turners = 300 Rupees

Single

1 Turner = 75 Rupees

Multiple

6 Turners = 6 x 75 = 450 Rupees

- One vehicle consumes 30 litres of petrol per day how much petrol is used by 6 Vehicles operating under similar condition.

One vehicle uses petrol = 30 litres per day.

Then six vehicles will use = 6 Times as much

= 6 x 30 = 180 litres/day.

- 4 vehicles consumes 120 gallons of petrol per day how much petrol will be used by 12 vehicles operating under the same condition.

4 vehicles use 120 gallons per day

1 Vehicle will use $\frac{120}{4} = 30$ gallons/day

12 vehicles will use 12 x 30 = 360 gallons/day

Both examples are called simple proportion because only two quantities were used and the day is common for both ratios.

- If 2 litres of petrol costs Rs 60. Find the cost of 50 litres.

Quantity of Petrol	Cost of Petrol
--------------------	----------------

2 litres	Rs.60
----------	-------

50 litres	x
-----------	-----

1 litre petrol = $\frac{60}{2} = \text{Rs.}30$

50 litres petrol = 30 x 50 = Rs 1500

- A 150mm dia gear meshes with 50mm dia gear. If the larger gear has 30 teeth. How many teeth will have the smaller gear have?

Gear dia	No. of Teeth
----------	--------------

150 mm	30
--------	----

50 mm	x
-------	-----

$x = \frac{50}{150} \times 30 = 10$ teeth.

- A mechanic assembles 7 machines in 2½ days. How long will it take time to assemble 70 machines at the same rate.

Machines	Days
----------	------

7	2½
---	----

70	x
----	-----

$x = \frac{70 \times 2.5}{7} = 25$ days

Assemble for 70 machines will take 25 days.

- A roll of wire weighs 1.24 kg from this roll a piece of 3.7cm long is cut and it is found to weigh 2.93 gm. What is the length of the wire in the roll?

Weight of wire	Length of wire
----------------	----------------

2.93 gm	3.7 cm
---------	--------

1.24 kg (1240 gm)	x
-------------------	-----

$$x = \frac{1240}{2.93} \times 3.7 = 1566 \text{ cm}$$

Length of wire = 1566 cm.

Indirect or inverse proportion

The more in one the lesser other - Increase in one quantity will produce a decrease in the other. (Fig 2)

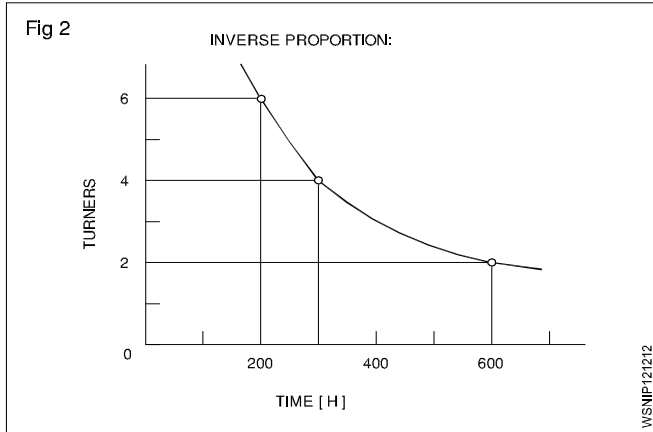

Example

- 1 4 turners finish a job in 300 hours. How much time will 6 turners take to do the same job?

Solution procedure in three steps:

Statement 4 turners taken = 300 hours

The time will reduce if 6 turners to do the same job. Therefore this is inverse proportion.

Multiple fraction $\frac{4 \text{ Turners}}{6 \text{ Turners}} \times 300 \text{ hours}$

6 Turners = 200 hours

Result - The more the less.

- 2 8 workman take 6 days to complete a job. How many days it will take for 4 workman to complete the same job?

Workman	Days
8	6
4	x

$$x = \frac{8}{4} \times 6 = 12 \text{ days}$$

4 workers complete the work = 12 days.

- 3 5 men working on a job finished it in 32 days. Find out in how many days 8 men will finish the same job?

Men	Days
5	32
8	x

$$x = \frac{5 \times 32}{8} = 4 \times 5 = 20 \text{ days}$$

8 men will complete the job = 20 days.

- 4 An engine running at 150 rpm drives a shaft by pulley diameter is 55cm and that of the driven shaft pulley is 33 cm. Find the speed of the shaft?

Dia of pulley	Rpm of shaft
55 cm	150
33 cm	x

$$x = \frac{55 \times 150}{33} = 250 \text{ rpm.}$$

Speed of the 33cm diameter will run 250 rpm.

- 5 A pulley of 80 cm diameter is rotating at 100 rpm and drives another pulley of 40 cm diameter. Find the rpm of driven pulley. If slip is 2.5% find the rpm?

Dia of pulley	Rpm of pulley
80 cm	100
40 cm	x

40 cm diameter = 200 rpm.

Slip is 2.5% = 195 rpm.

Problems involving both

Example

2 turners need 3 days to produce 20 pieces. How long will it take for 6 turners to produce 30 such pieces?

Statement

2 turners, 20 pieces = 3 days

6 turners, 30 pieces = how many days.

First step (Fig 3)

Statement 2 turners for 20 pieces = 3 days

1 turner for 20 pieces = $3 \times 2 = 6$ days

Multiple 6 turners for 20 pieces = $\frac{6}{6} = 1$ day

Statement 6 turners for 20 pieces = 1 day

Single 6 turners for 1 piece = $\frac{1}{20}$ days

Multiple 6 turners for 30 pieces = $\frac{1}{20} \times 30 = 1.5$ days

Inverse proportion - More the less.

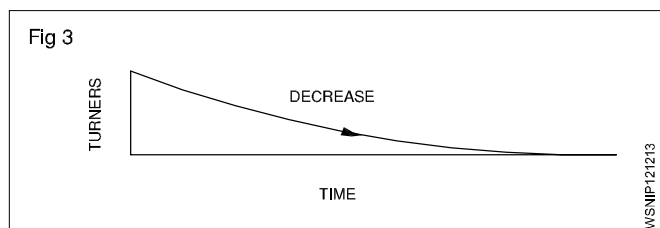

Second step (Fig 4)

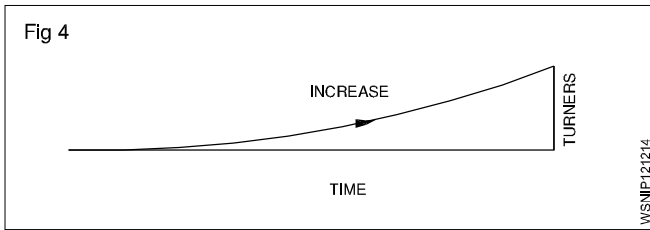

Direct proportion - More the more.

Solve the problem by first writing the statement and proceed to single and then to the multiple according to the type of proportion that is involved.

Introduction

Proportional fundamentals, as applicable to motor vehicle calculations are discussed below.

Simple Proportion

- Proportion

This is an equality between two ratios

Compound and Inverse proportions

- Compound proportions

Example

5 Fitter take 21 days to complete overhauling of 6 vehicles how long 7 Fitters will take to over haul 8 vehicles (Assume time of overhauling each vehicle is constant)

In this both direct and indirect proportions are used.

- 1 Fitter will overhauling 1 vehicle in days (shorter time).
- Quantities (No. of days) are taken in last as that is the answer required in this case.

Fitters	Vehicle	Days
5	6	21
7	8	x

$$\left(\frac{21 \times 5}{6 \times 7} \times 8\right) = 20 \text{ days}$$

Ans: 7 Fitters will overhaul 8 vehicles in 20 days.

Inverse proportion

Some times proportions are taken inversely.

Examples

- If one water pump fills the fuel tank in 12 minutes, two pumps will take half the time taken.

The time should not be doubled.

- 2 pumps will take 30 minutes to fill up a tank how long will 6 similar pumps take this to fill this tank.

Pump	Time
2	30
6	x

Ans: Time taken by 6 pumps = $\frac{30 \times 2}{6} = 10 \text{ minutes}$

Assignment

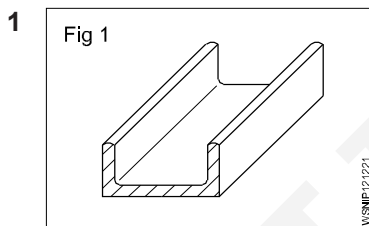

Length = 6.1 metre
Weight = 32 kgf
Weight of 1 metre of the same channel = _____ kgf

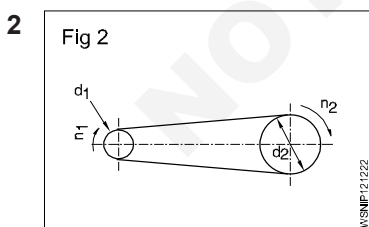

d₁ = 120 mm
d₂ = 720 mm
n₁ = 1200 rpm
n₂ = _____ rpm

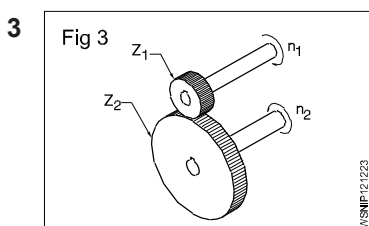

Z₁ = 42 T
n₂ = 96 rpm
n₁ = 224 rpm
Z₂ = _____ T

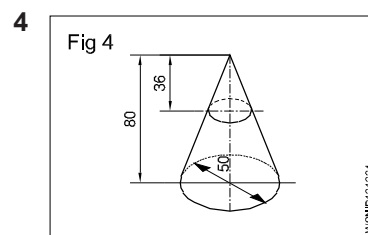

D = 50 mm
H = 80 mm
h = 36 mm
d = _____ mm

- If a mechanic assembles 8 machines in 3 days, how long he will take to assemble 60 machines.
- In an auto shop the grinding wheel makes 1000 rpm and the driven pulley is 200 mm dia. If the driving pulley is 150 mm dia. Find out the rpm of the driving pulley.
- In a gearing of a vehicle the following facts are found. A 180 mm dia of gear meshes with 60mm dia gear. If the bigger gear makes 60 rpm. What will be the rpm of smaller gear.
- A vehicular job is completed by 5 mechanics in 4 days. If only 3 mechanics are available, in how many days the work can be completed.

Square root, Ratio and Proportions, Percentage - Percentage

Percentage

Percentage is a kind of fraction whose denominator is always 100. The symbol for percent is %, written after the number. e.g. 16%.

Ex. $\frac{16}{100} = 0.16$

In decimal form, it is 0.16. Percentage calculation also involves rule of three. The statement (the given data), for unit, and then to multiple which is for calculating the answer. (Fig 1)

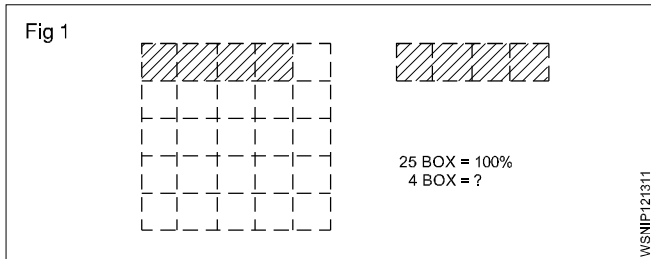

Example

The amount of total raw sheet metal to make a door was 3.6 metre² and wastage was 0.18 metre². Calculate the % of wastage. (Fig 2)

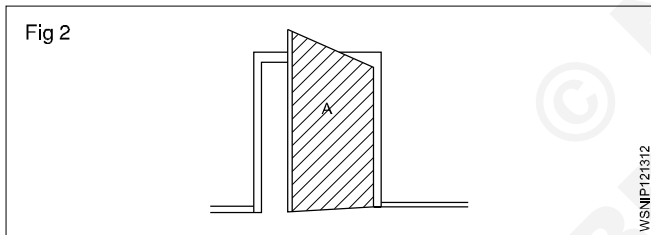

Solution procedure in three steps.

Statement:

Area of door (A) = 3.6 m² = 100 %.

Wastage = 0.18 m²

Single: $\frac{100}{3.6} \times 1 \text{ m}^2$

Multiple: for 0.18 m² = $\frac{100}{3.6} \times 0.18$.

Wastage = 5%.

Analyse the given data and proceed to arrive at the answer through the unit.

Example

A fitter receives a take-home salary of 984.50 rupees.

If the deduction amounts to 24%, what is his total salary? (Fig 3)

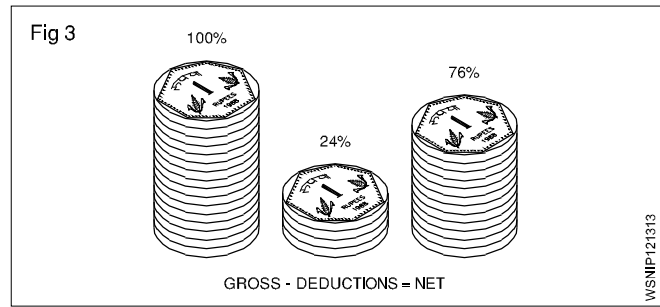

Total pay 100%

Deduction 24%

Take home salary 76%

If the take home pay is Rs.76, his salary is 100.

For 1% it is $\frac{1}{76}$

For Rs.984.50, it is $\frac{1}{76} \times 984.50$.

For 100% it is $\frac{984.50}{76} \times 100 = 1295.39$

100% i.e. gross pay = Rs.1295.40.

Example 1

75 litres of oil is taken out from a oil barrel of 200 litres capacity. Find out the percentage taken in this.

Solution

% of oil taken = Oil taken out (litres) / Capacity of Barrel (litres) x 100

$= \frac{75}{200} \times 100 = 37\frac{1}{2}\%$

Example 2

A spare part is sold with 15%. Profit to a customer, to a price of Rs.15000/-. Find out the following (a) What is the purchase price (b) What is the profit.

Solution: CP = x ,

CP = cost price

SP = sale price

SP=CP+15%of CP

$15000 = x + \frac{15x}{100} = \frac{100x + 15x}{100}$

$x = \frac{1500000}{115} = 13043.47$

Profit = SP-CP = 15000-13043.47 = 1956.53

Purchase price = Rs.13,043/, Profit = Rs. 1957

Example 3

Out of 80000 cars, which were tested on road, only 16000 cars had no fault. What is the percentage in this acceptance.

$$= \frac{16000}{80000} \times 100 = \frac{100}{5} = 20\%$$

Example 4

The price of a motor cycle dropped to 92% of original price and now sold at Rs. 18000/- What was the original price.

Solution

Present price of Motor cycle Rs. 18000

This is the value of 92% of original price

$$\text{Original Price} = 18000 \times \frac{100}{92} = \frac{1800000}{92}$$

$$= \text{Rs. } 19565$$

Example 5

A Motor vehicle uses 100 litres of Petrol per day when travelling at 30 kmph. After top overhauling the consumption falls to 90 litres per day. Calculate percentage of saving.

Solution

Percentage of saving = Decrease in consumption / Original consumption x 100

$$= (100 - 90) \frac{\text{litres}}{100} \times 100$$

$$= \frac{10}{100} \times 100$$

= 10% Saving in fuel.

Assignment

1

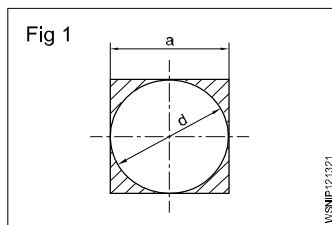

a = 400mm (side of square)
d = 400 mm
Wastage = _____ %.

2

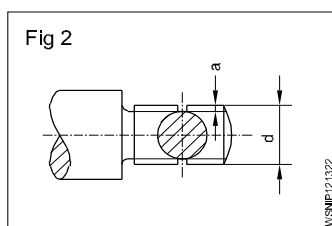

d = 26mm
'a' depth of u/cut = 2.4mm
reduction of area at cross-section = _____ %

3

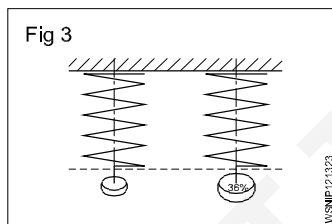

Percentage of increase = 36%
Value of increase = 611.2 N/mm²
Original tensile strength = _____ N/mm².

4

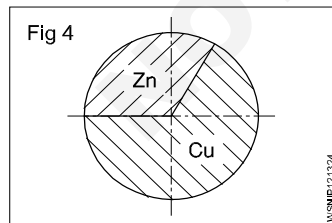

Copper in alloy = 27 kg
Zinc in alloy = 18 kg
% of Copper = _____ %
% of Zinc = _____ %.

5

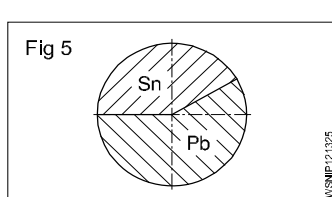

Weight of alloy = 140 Kgf
Weight of Sn 40%
Pb = _____ Kgf
Sn = _____ Kgf.

6

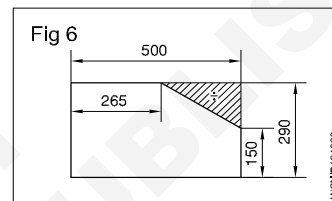

Shaded portion = _____ %.

7

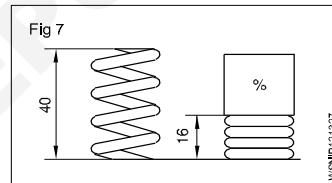

Compression length = _____ %.

8

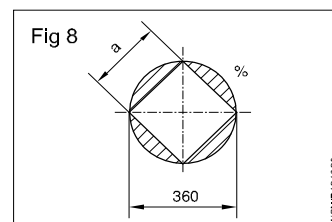

d = 360 mm
a = 0.707 x d
Wastage = _____ %.

9

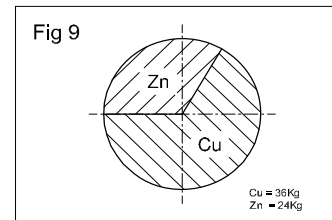

Cu = 36 Kg
Zn = 24 Kg
Cu = _____ %
Zn = _____ %

10

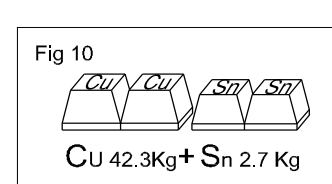

Cu = 42.3 Kg
Sn = 2.7 Kg
Cu _____ %
Sn = _____ %.

Square root, Ratio and Proportions, Percentage - Changing percentage to decimal and fraction

Conversion of Fraction into Percentage

1 Convert $\frac{1}{2}$ into percentage.

$$\begin{aligned}\text{Solution: } \frac{1}{2} \times 100 \\ &= 50\%\end{aligned}$$

2 Convert $\frac{1}{11}$ into percentage

$$\begin{aligned}\text{Solution: } \frac{1}{11} \times 100 &= \frac{100}{11} \\ &= 9.01\%\end{aligned}$$

Convert the following fraction into percentage.

1 $\frac{1}{4}$

2 $\frac{1}{5}$

3 $\frac{2}{3}$

4 $\frac{3}{8}$

Conversion of Percentage into Fraction

1 Convert 24% into fraction.

$$\text{Solution: } \frac{24}{100} = \frac{6}{25}$$

2 Convert $33\frac{1}{3}\%$ into fraction.

$$\begin{aligned}\text{Solution: } \frac{33\frac{1}{3}}{100} &= \frac{\frac{100}{3}}{100} = \frac{100}{3} \times \frac{1}{100} \\ &= \frac{1}{3}\end{aligned}$$

Convert the following percentage into fraction

1 15%

2 $87\frac{1}{2}\%$

3 80%

4 12.5%

Conversion of Decimal Fraction into Percentage

1 Convert 0.35 into percentage.

$$\begin{aligned}\text{Solution: } 0.35 \times 100 \\ &= 35\%\end{aligned}$$

2 Convert 0.375 into percentage.

$$\begin{aligned}\text{Solution: } 0.375 \times 100 \\ &= 37.5\%\end{aligned}$$

Convert the following Decimal Fraction into Percentage

1 0.2

2 0.004

3 0.875

4 0.052

Conversion of Percentage into Decimal fraction

1 Convert 30% into decimal fraction.

$$\text{Solution: } \frac{30}{100} = 0.3$$

2 Convert $33\frac{1}{3}\%$ into decimal fraction.

$$\begin{aligned}\text{Solution: } \frac{33\frac{1}{3}}{100} &= \frac{\frac{100}{3}}{100} = \frac{100}{3} \times \frac{1}{100} \\ &= \frac{1}{3} = 0.333\end{aligned}$$

Convert the following percentage into decimal fraction

1 15%

2 7%

3 $12\frac{1}{2}\%$

4 90%

Material science - Types of metal, types of ferrous and non ferrous metals**Types of metals**

The metals is of two types:

- 1 Ferrous metal 2 Non-ferrous metal

1 Ferrous metals : The metals that contains major part of iron and contain carbon are called ferrous metals such as pig iron, mild steel, nickel etc., they have iron properties such as rusting, magnetisations etc.

2 Non-ferrous metals : The metals that do not contains iron or carbon and do not have the property of iron are called non-ferrous metals such as copper, aluminum etc.

Ferrous and Non ferrous alloys**Alloying metals and ferrous alloys**

An alloy is formed by mixing two or more metals together by melting.

For ferrous metals and alloys, iron is the main constituent metal. Depending on the type and percentage of the alloying metal added, the property of the alloy steel will vary.

Metals commonly used for making alloy steels**Nickel (Ni)**

This is a hard metal and is resistant to many types of corrosion rust.

It is used in industrial applications like nickel, cadmium batteries, boiler tubes, valves of internal combustion engines, engine spark plugs etc. The melting point of nickel is 1450°C. Nickel can be magnetised. In the manufacture of permanent magnets a special nickel steel alloy is used. Nickel is also used for electroplating. Invar steel contains about 36% nickel. It is tough and corrosion resistant. Precision instruments are made of Invar steel because it has the least coefficient of expansion.

Nickel-steel alloys are available containing nickel from 2% to 50%.

Chromium (Cr)

Chromium, when added to steel, improves the corrosion resistance, toughness and hardenability of steel. Chromium steels are available which may contain chromium up to 30%.

Chromium, nickel, tungsten and molybdenum are alloyed for making automobile components and cutting tools.

Chromium is also used for electroplating components. Cylinder liners are chrome-plated inside so as to have wear resistance properties. Stainless steel contains about 13% chromium. Chromium-nickel steel is used for bearings. Chrome-vanadium steel is used for making hand tools like spanners and wrenches.

Manganese (Mn)

Addition of manganese to steel increases hardness and strength but decreases the cooling rate.

Manganese steel can be used to harden the outer surface for providing a wear resisting surface with a tough core. Manganese steel containing about 14% manganese is used for making agricultural equipment like ploughs and blades.

Silicon (Si)

Addition of silicon for alloying with steel improves resistance to high temperature oxidation.

This also improves elasticity, and resistance against corrosion. Silicon alloyed steels are used in manufacturing springs and certain types of steel, due to its resistance to corrosion. Cast iron contains silicon about 2.5%. It helps in the formation of free graphite which promotes the machinability of cast iron.

Tungsten (W)

The melting temperature of tungsten is 3380°C. This can be drawn into thin wires.

Due to this reason it is used to make filaments of electric lamps.

Tungsten is used as an alloying metal for the production of high speed cutting tools. High speed steel is an alloy of 18% tungsten, 4% chromium and 1% vanadium.

Stellite is an alloy of 30% chromium, 20% tungsten, 1 to 4% carbon and the balance cobalt.

Vanadium (Va)

This improves the toughness of steel. Vanadium steel is used in the manufacture of gears, tools etc. Vanadium helps in providing a fine grain structure in tool steels.

Chrome-vanadium steel contains 0.5% to 1.5% chromium, 0.15% to 0.3% vanadium, 0.13% to 1.10% carbon.

This alloy has high tensile strength, elastic limit and ductility. It is used in the manufacture of springs, gears, shafts and drop forged components.

Vanadium high speed steel contains 0.70% carbon and about 10% vanadium. This is considered as a superior high speed steel.

Cobalt (Co)

The melting point of cobalt is 1495°C. This can retain magnetic properties and wear-resistance at very high temperatures. Cobalt is used in the manufacture of magnets, ball bearings, cutting tools etc. Cobalt high speed steel (sometimes known as super H.S.S.) contains about 5 to 8% cobalt. This has better hardness and wear resistance properties than the 18% tungsten H.S.S.

Molybdenum (Mo)

The melting point of molybdenum is 2620°C. This gives high resistance against softening when heated. Molybdenum high speed steel contains 6% of molybdenum, 6% tungsten, 4% chromium and 2% vanadium. This high speed steel is very tough and has good cutting ability.

Cadmium (cd)

The melting point of cadmium is 320°C. This is used for coating steel components.

Alloying Metals and Non Ferrous Alloys

Non-ferrous Metals And Alloys

Copper and its alloys

Metals without iron are called non-ferrous metals. Eg. Copper, Aluminium, Zinc, Lead and Tin.

Copper

This is extracted from its ores 'MALACHITE' which contains about 55% copper and 'PYRITES' which contains about 32% copper.

Properties

Reddish in colour. Copper is easily distinguishable because of its colour.

The structure when fractured is granular, but when forged or rolled it is fibrous.

It is very malleable and ductile and can be made into sheets or wires.

It is a good conductor of electricity. Copper is extensively used as electrical cables and parts of electrical apparatus which conduct electric current.

Copper is a good conductor of heat and also highly resistant to corrosion. For this reason it is used for boiler fire boxes, water heating apparatus, water pipes and vessels in brewery and chemical plants. Also used for making soldering iron.

The melting temperature of copper is 1083°C.

The tensile strength of copper can be increased by hammering or rolling.

Copper Alloys

Brass

It is an alloy of copper and zinc. For certain types of brass small quantities of tin or lead are added. The colour of brass depends on the percentage of the alloying elements. The colour is yellow or light yellow, or nearly white. It can be easily machined. Brass is also corrosion-resistant.

Brass is widely used for making motor car radiator core and water taps etc. It is also used in gas welding for hard soldering/brazing. The melting point of brass ranges from 880 to 930°C.

Brasses of different composition are made for various applications.

Bronze

Bronze is basically an alloy of copper and tin. Sometimes zinc is also added for achieving certain special properties. Its colour ranges from red to yellow. The melting point of bronze is about 1005°C. It is harder than brass. It can be easily machined with sharp tools. The chip produced is granular. Special bronze alloys are used as brazing rods.

Bronze of different compositions are available for various applications.

Lead and its alloys

Lead is a very commonly used non-ferrous metal and has a variety of industrial applications.

Lead is produced from its ore 'GALENA'. Lead is a heavy metal that is silvery in colour when molten. It is soft and malleable and has good resistance to corrosion. It is a good insulator against nuclear radiation. Lead is resistant to many acids like sulphuric acid and hydrochloric acid.

It is used in car batteries, in the preparation of solders etc. It is also used in the preparation of paints.

Lead Alloys

Babbitt metal

Babbitt metal is an alloy of lead, tin, copper and antimony. It is a soft, anti-friction alloy, often used as bearings.

An alloy of lead and tin is used as 'soft solder'.

Zinc and its alloys

Zinc is a commonly used metal for coating on steel to prevent corrosion. Examples are steel buckets, galvanized roofing sheets, etc.

Zinc is obtained from the ore-calamine or blende.

Its melting point is 420° C.

It is brittle and softens on heating; it is also corrosion-resistant. Due to this reason it is used for battery containers and is coated on roofing sheets etc.

Galvanized iron sheets are coated with zinc.

Tin and tin alloys

Tin

Tin is produced from cassiterite or tinstone. It is silvery white in appearance, and the melting point is 231° C. It is soft and highly corrosion-resistant.

It is mainly used as a coating on steel sheets for the production of food containers. It is also used with other metals, to form alloys.

Example: Tin with copper to form bronze. Tin with lead to form solder. Tin with copper, lead and antimony to form Babbitt metal.

Aluminium

Aluminium is a non-ferrous metal which is extracted from 'BAUXITE'. Aluminium is white or whitish grey in colour. It has a melting point of 660° C. Aluminium has high electrical and thermal conductivity. It is soft and ductile, and has low tensile strength. Aluminium is very widely used in aircraft industry and fabrication work because of its lightness. Its application in the electrical industry is also on the increase. It is also very much in use in household heating appliances.

Material science - Physical and mechanical properties of metals

Metal:

Metal is a mineral used in all types of engineering works such as machineries, bridges, aero planes etc., so we must have basic knowledge about the metals.

Understanding the physical and mechanical properties of metals has become increasingly important for a machinist since he has to make various components to meet the designed service requirements against factors, such as the raise of temperature, tensile, compressive and impact loads etc. A knowledge of different properties of materials will help him to do his job successfully. If proper material/metal is not used it may cause fracture or other forms of failures, and endanger the life of the component when it is put into function.

Fig 1 shows the way in which the metals get deformed when acted upon by the same load.

Note the difference in the amount of deformation.

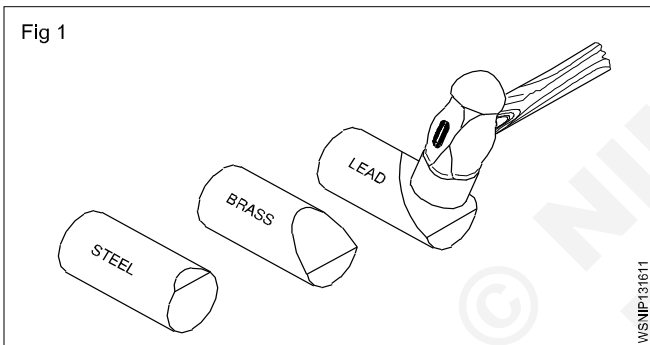

Physical properties of metals

- Colour
- Weight/specific gravity
- Structure
- Conductivity
- Magnetic property
- Fusibility

Colour

Different metals have different colours. For example, copper is distinctive red colour. Mild steel is blue/black sheen.

Weight

Metals may be distinguished, based on their weights for given volume. Metals like aluminium lighter weight (Specific gravity 2.7) and metals like lead have a higher weight. (Specific gravity 11.34)

Structure (Figs 2&3)

Generally metals can also be differentiated by their internal structures while seeing the cross-section of the bar through a microscope. Metals like wrought iron and aluminium have a fibrous structure and metals like cast Iron and bronze have a granular structure.

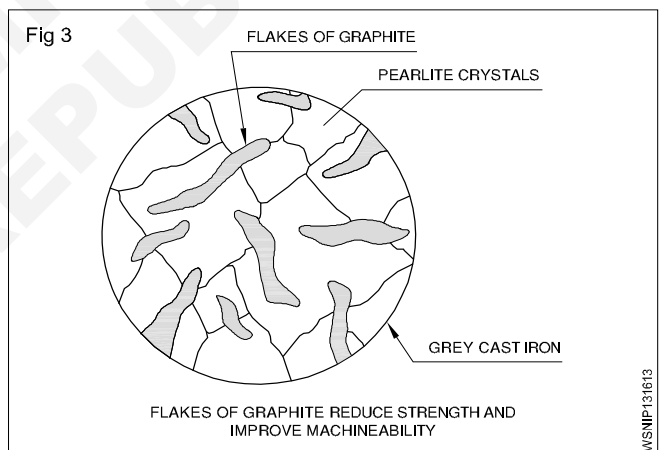
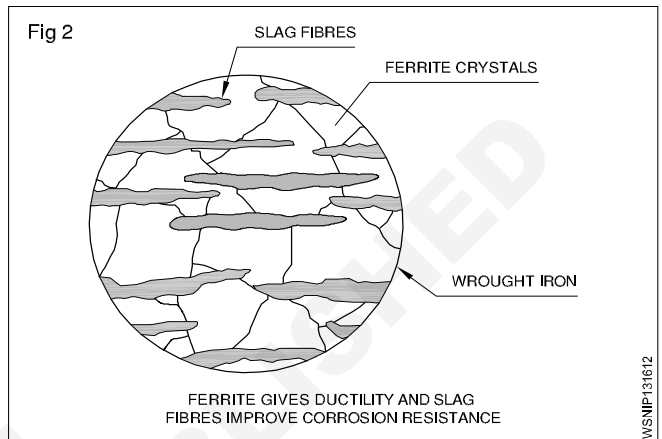

Conductivity (Figs 4&5)

Thermal conductivity and electrical conductivity are the measures of ability of a material to conduct heat and electricity. Conductivity will vary from metal to metal. Copper and aluminium are good conductors of heat and electricity.

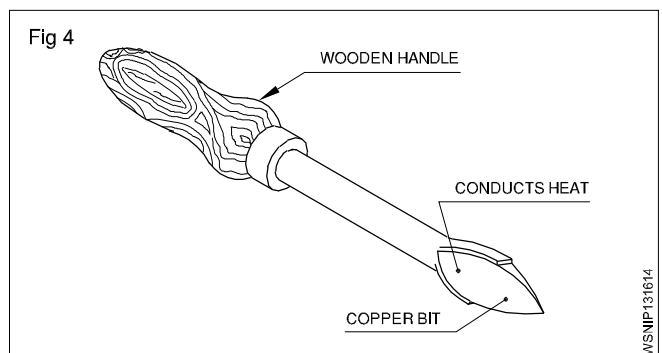

WSNIP131612

WSNIP131613

WSNIP131614

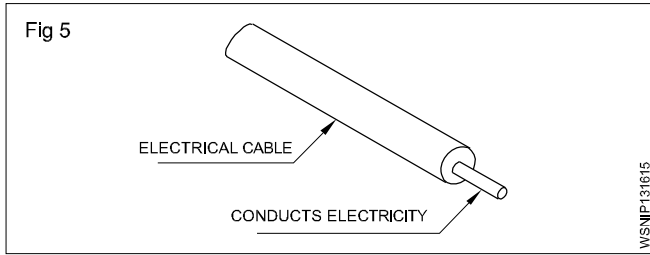

Magnetic property

A metal is said to possess a magnetic property if it is attracted by a magnet.

Almost all ferrous metals, except some types of stainless steel, can be attracted by a magnet, and all non-ferrous metals and their alloys are not attracted by a magnet.

Fusibility (Fig 6)

It is the property possessed by a metal by virtue of which it melts when heat is applied. Many materials are subject to transformation in the shape (i.e) from solid to liquid at different temperatures. Lead has a low melting temperature while steel melts at a high temperature.

Tin melts at 232°C.

Tungsten melts at 3370°C.

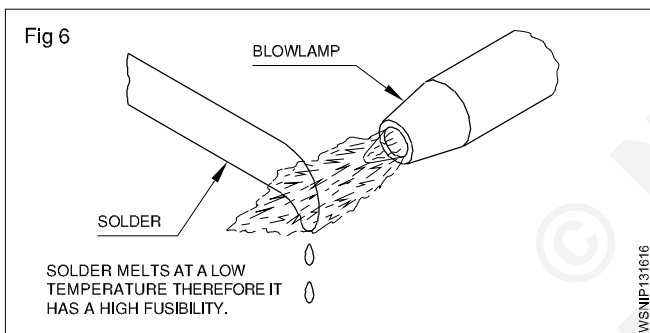

Mechanical properties

- Ductility
- Malleability
- Hardness
- Brittleness
- Toughness
- Tenacity
- Elasticity

Ductility (Fig 7)

A metal is said to be ductile when it can be drawn out into wires under tension without rupture. Wire drawing depends upon the ductility of a metal. A ductile metal must be both strong and plastic. Copper and aluminium are good examples of ductile metals.

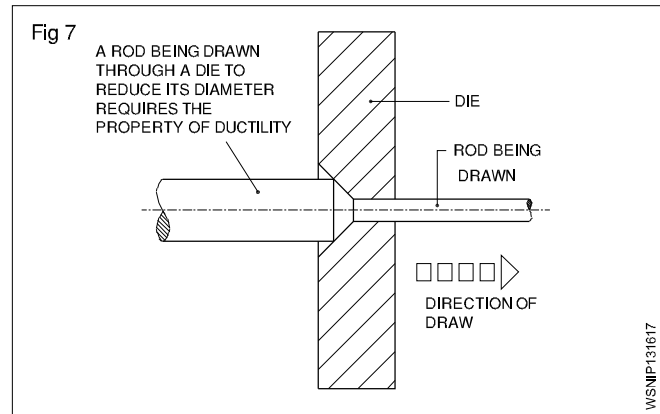

Malleability (Figs 8 and 9)

Malleability is the property of a metal by which it can be extended in any direction by hammering, rolling etc. without causing rupture. Lead is an example of a malleable metal.

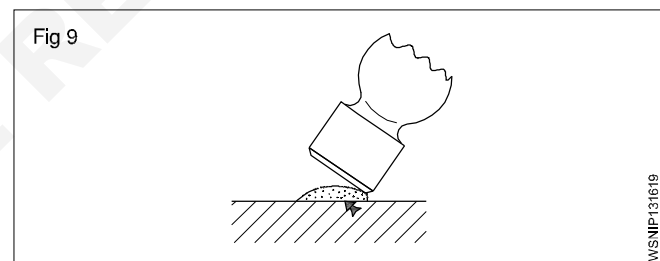
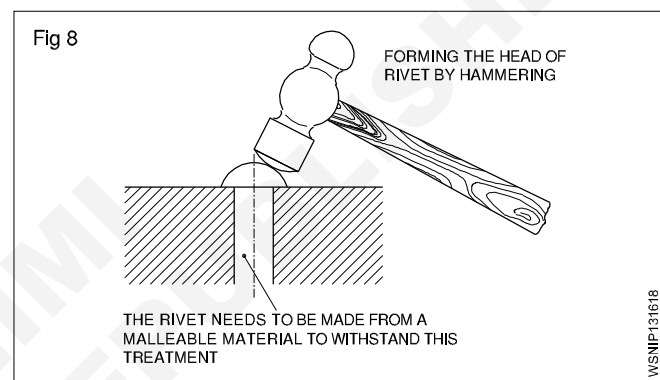

Hardness (Fig 10)

Hardness is a measure of a metal's ability to withstand scratching, wear and abrasion, indentation by harder bodies. The hardness of a metal is tested by marking by a file etc.

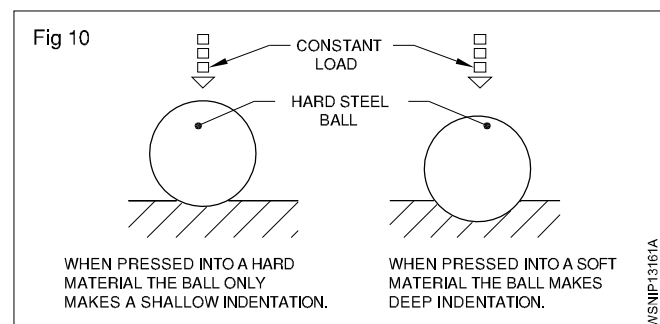

Brittleness (Fig 11)

Brittleness is that property of a metal which permits no permanent distortion before breaking. Cast iron is an example of a brittle metal which will break rather than bend under shock or impact.

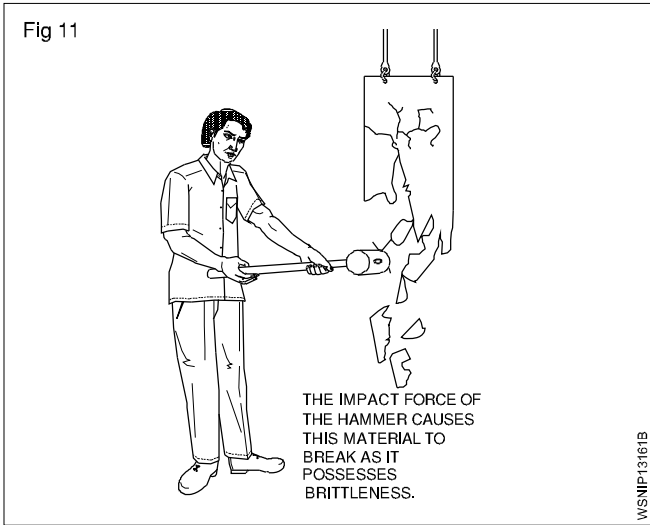

Toughness (Fig 12)

Toughness is the property of a metal to withstand shock or impact. Toughness is the property opposite to brittleness. Wrought iron is an example of a tough metal.

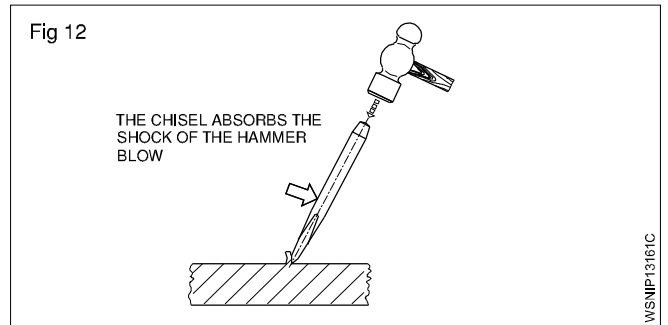

Tenacity

The tenacity of a metal is its ability to resist the effect of tensile forces without rupturing. Mild steel, Wrought Iron and copper are some examples of tenacious metals.

Elasticity

Elasticity of a metal is its power of returning to its original shape after the applied force is released. Properly heat-treated spring is a good example for elasticity.

Material science - Introduction of iron and cast iron

Ferrous Metals

Metals which contain iron as a major content are called ferrous metals. Ferrous metals of different properties are used for various purposes.

Introduction of Iron, Cast Iron, wrought Iron and steel

The ferrous metals and alloys used commonly are:

- Pig-iron
- Cast Iron
- Wrought Iron
- Steels and Alloy steels

Different processes are used to produce iron and steel.

Pig-iron (Manufacturing process)

Pig-iron is obtained by the chemical reduction of iron ore. This process of reduction of the iron ore to Pig-iron is known as SMELTING.

The main raw materials required for producing Pig-iron are:

- Iron ore
- Coke
- Flux

Iron ore

The chief iron ores used are:

- magnetite
- hematite
- limonite
- carbonite.

These ores contain iron in different proportions and are naturally available.

Coke

Coke is the fuel used to give the necessary heat to carry on the reducing action. The carbon from the coke in the form of carbon monoxide combines with the iron ore to reduce it to iron.

Flux

This is the mineral substance charged into a blast furnace to lower the melting point of the ore, and it combines with the non-metallic portion of the ore to form a molten slag.

Limestone is the most commonly used flux in the blast furnace.

Properties and use of Pig-iron

Pig-iron is, therefore, refined and remelted and used to produce other varieties of iron and steel.

Cast Iron (Manufacturing process)

The pig-iron which is tapped from the blast furnace is the crude form of raw material for the cupola, and should be further refined for making castings. This refining is carried out in the cupola furnace which is a small form of a blast furnace.

Generally cupolas are not worked continuously like blast furnaces but are run only as and when required.

Cast Iron (Types)

Cast iron is an alloy of iron, carbon and silicon. The carbon content ranges from 2 to 4%.

Types of cast iron

The following are the types of cast iron.

- Grey cast iron
- White cast iron
- Malleable cast iron
- Nodular cast iron

Grey cast iron

This is widely used for the casting of machinery parts and can be machined easily.

Machine base, tables, slideways are made of cast iron because it is dimensionally stable after a period of aging.

Because of its graphite content, cast iron provides an excellent bearing and sliding surface.

The melting point is lower than that of steel and as grey cast iron possesses good fluidity, intricate casting can be made.

Grey cast iron is widely used for machine tools because of its ability to reduce vibration and minimize tool chatter.

Grey cast iron, when not alloyed, is quite brittle and has relatively low tensile strength. Due to this reason it is not used for making components subjected to high stress or impact loads.

Grey cast iron is often alloyed with nickel, chromium, vanadium or copper to make it tough.

Grey cast iron is weldable but the base metal needs preheating.

White cast iron

This is very hard and is very difficult to machine, and for this reason, it is used in components which should be abrasion-resistant.

White cast iron is produced by lowering the silicon content and by rapid cooling. When cooled in this manner, it is called chilled cast iron.

White cast iron cannot be welded.

Malleable cast iron

Malleable cast iron has increased ductility, tensile strength and toughness when compared with grey cast iron.

Malleable cast iron is produced from white cast iron by a prolonged heat-treatment process lasting for about 30 hours.

Nodular cast iron

This is very similar to malleable cast iron. But this is produced without any heat treatment. Nodular cast iron is also known as: **Nodular Iron - Ductile Iron - Spheroidal Graphite Iron**

This has good machinability, castability, resistance to wear, low melting point and hardness.

Malleable and nodular castings are used for machine parts where there is a higher tensile stress and moderate impact loading. These castings are less expensive and are an alternative to steel castings.

Wrought Iron (Manufacturing process) (Fig 1)

Wrought iron is the purest form of iron. The analysis of Wrought iron shows as much as 99.9% of iron. (Fig 1) When heated, wrought iron does not melt, but only becomes pasty and in this form it can be forged to any shape.

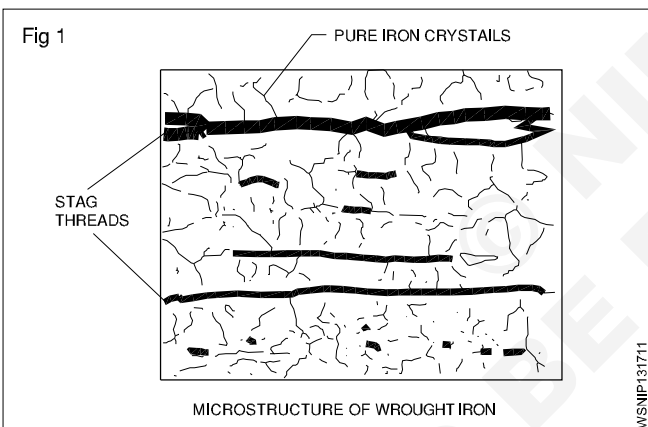

Modern methods used to produce wrought iron in large quantities are the

- puddling process
- aston or Byers process

Steel

This is pure iron. Carbon content is more. Due to excessive carbon it is harder and tougher. Carbon content is from 0.15 to 1.5%. Besides there are other impurities like sulphur, phosphorous etc. are there which cannot be separated. This is hardened and tempered by heating it to a definite temperature and cooling it in oil or water.

The following methods are adopted for making different types of steel:

- 1 Cementation process
- 2 Crucible process
- 3 Bessemer process
- 4 Open hearth process
- 5 Electro thermo process
- 6 High frequency process.

Types of steel

Main two types of steel are:

- 1 Plain steel
- 2 Alloy steel

1 Plain steel. In this carbon and iron are mixed. According to the percentage of carbon plain steels are classified as:

- A Low carbon steel
- B Medium carbon steel
- C High carbon steel

A Low carbon steel: It is also called mild steel. In this, the percentage of carbon is from 0.15% to 0.25%. Due to less quantity of carbon is sufficiently soft and tolerates the strain. It can be put in different shapes through forging and rolling. This is not very hard or strong. This cannot be hardened or tempered by ordinary methods. Nuts, bolts, rivets, sheets, wires, T-iron and angle iron etc. are made out of it.

B Medium carbon steel: The carbon content is from 0.25% to 0.5%. Due to excess of carbon, it is harder and tougher than mild steel. The tenacity is more. This can be hardened or tempered. Various things are made by forging and rolling. This is used for making high tensile tubes, wires, agricultural implements, connecting rods, cam shafts, spanners, pulleys etc.

C High carbon steel: It has carbon content from 0.5% to 1.5%. It is very hard and wears least. This can be hardened by heat treatment. This can neither be cast nor rolled. This is very hard and tough. It acquires permanent magnetic properties. This is used for making pointed tools, springs, pumps, files, cutleries, cold chisels press die etc.

2 Alloy Steel

When the steel is mixed with other metals like vanadium, manganese tungsten etc., it is called an alloy steel. Alloy steel has properties of its ingredients.

Types of Alloy Steel

Two types of alloy steel are:

- A Low alloy steel
- B High alloy steel

A Low Alloy steel: Besides carbon other metals are in lesser quantity. Its tensile strength is more. The welding can work on it. This can also be hardened and tempered. It is used in manufacturing various parts of an aeroplane and cam shaft etc.

B High Alloy Steel: Besides carbon it has a high percentage of the metals higher than low steel alloy. This is classified into following types:

a High Speed Steel: It is also called high tungsten alloy steel because it has more quantity of tungsten. According to the quantity of tungsten it is classified into three types:

- 1 Tungsten 22%, Chromium 4%, Vanadium 1%
- 2 Tungsten 18%, Chromium 4%, Vanadium 1%
- 3 Tungsten 14%, Chromium 4%, Vanadium 1%

Cutting tools are made out of it because it is very hard but becomes soft at low critical temperature. This temperature is raised out of cutting process of tool, then the cutting tool becomes useless and is unfit for work. But due to high percentage of tungsten it keeps working upto high temperature. It is used for cutting tools, drills, cutters, reamers, hacksaw blades etc.

b Nickel Steel: In this 0.3% carbon and 0.25 to 0.35% nickel is present. Due to nickel its tensile strength, elastic limit and hardness is increased. It does not catch rust. Its cutting resistance increases 6 times more than plain carbon and steel due to 0.35% nickel present in it. This is used for making rivets, pipes, axle shafting, parts of buses and aeroplanes. If 5% of cobalt is mixed with 30-35% nickel, it becomes invar steel. It is mainly used for making precious instruments.

c Vanadium Steel: It contains 1.5% carbon 12.5% tungsten, 4.5% chromium, 5% vanadium and 5% cobalt. Its elastic limit, tensile strength and ductility is more. It has strength to bear sharp jerks. It is mainly used to manufacture of tools.

d Manganese Steel: It is also called special high alloy steel. It contains 1.6 to 1.9% of manganese

and 0.4 to 0.5% carbon. It is hard and less wear. It is not affected by magnet. It is used in grinders and rail points etc.

e Stainless Steel: Along with iron it contains 0.2 to 0.6% carbon, 12 to 18% chromium, 8% nickel and 2% molybdenum. It is used for making knives, scissors, utensils, parts of aeroplane, wires, pipes and gears etc.

Properties of stainless steel:

- 1 Higher corrosion resistance
- 2 Higher cryogenic toughness
- 3 Higher work hardening rate
- 4 Higher hot strength
- 5 Higher ductility
- 6 Higher strength and hardness
- 7 More attractive appearance
- 8 Lower maintenance

f Silicon Steel: It contains 14% of silicon. Its uses are multifarious according to the percentage of silicon. 0.5% to 1% silicon, 0.7 to 0.95% manganese mixture is used for construction work. 2.5 to 4% silicon content mixture is used for manufacturing electric motors, generators, laminations of transformers. In chemical industries 14% silicon content mixture is used.

g Cobalt Steel: High carbon steel contains 5 to 35% cobalt. Toughness and tenacity is high. It has magnetic property therefore used to make permanent magnets.

Material science - Difference between iron & steel, alloy steel and carbon steel

Difference between iron and steel:

S.No	Basic distinction	Iron	Steel
1	Formation	Pure substance	Made up of iron and carbon
2	Types	Cast iron, Wrought iron and steel	Carbon steel and alloy steel
3	Rusting	Quickly gets oxidised and result in rust	Have different elements that protect from rusting
4	Surface	Its surface is rusty	Its surface stays shiny
5	Usage	Used in buildings, tools and automobiles	Used in buildings, cars, railways and automobiles
6	Existence	Available in nature	Has to be formed

Steel Plants in India

S.No	Name of the Steel plant	State
1	Tata Iron	Bihar
2	Indian Iron Steel	West Bengal
3	Vishweshvaraiyah Iron Steel	Karnataka
4	Bhilai Steel Plant	Chhattisgarh
5	Durgapur Steel Plant	West Bengal
6	Alloy Steel Plant (Durgapur)	West Bengal
7	Bokaro Steel Plant	Bihar
8	Rourkela Steel Plant	Orissa
9	Salem Steel Plant	Tamilnadu
10	Visakhapatnam Steel Plant	Andhra Pradesh

Comparison of the Properties of Cast Iron, Mild Steel and steel

Property	Cast Iron	Mild Steel	Steel
Composition	Carbon contents from 2 to 4.5%	Carbon contents from 0.1 to 0.25%	Carbon contents from 0.5 to 1.7%
Strength	- High compressive strength - Poor tensile strength - Poor shearing strength	- Moderate compressive strength - Moderate tensile strength - High shearing strength	- High compressive strength - High tensile strength - High shearing strength
Malleability	Poor	High	High
Ductility	Poor	High	High
Hardness	Moderately hard and can be hardened by heating to hardening temperature and quenching	Mild	Hard
Toughness	Possesses poor toughness	Very tough with carbon content	Toughness varies
Brittleness	Brittle	Malleable	Malleable
Forgeability	Cannot be forged	Can be forged	Can be forged
Weldability	Cannot be welded with difficulty	Can be welded very easily	Can be welded
Casting	Can be easily cast	Can be cast but not easily	Can be cast
Elasticity	Poor	High	High

Ferrous metals	Non Ferrous metals
1 Iron content is more	1 Iron content is missing
2 The melting point is high	2 The melting point is low.
3 This is of brown and black colour	3 This is of different colours
4 This catches rust	4 This doesn't catch rust.
5 This can be magnetised	5 This cannot be magnetised
6 This is brittle in cold state.	6 This becomes brittle in hot state.

Difference between cast Iron and steel

Cast Iron	Steel
1 Carbon content is high	Carbon content is less
2 Carbon is in free state	Carbon is mixed
3 Melting point is low	Melting point is high
4 It cannot be magnetised	It can be magnetised
5 Because it is brittle, it cannot be forged	It can be forged
6 It rusts with difficulty	It rusts quickly
7 It cannot be welded	It can be welded

Difference between metals and non-metals

Metals	Non Metals
Shiny	Dull
Usually good conductors of heat and electricity	Usually poor conductors of heat and electricity
Most are ductile	Not ductile
Opaque (opposite of 'transparent')	Transparent when as a thin sheet
Most are malleable	Usually brittle when solid
Form alkaline oxides	Form acidic oxides
Sonorous (make a bell-like sound when struck)	Not sonorous
Usually have 1-3 valence electrons	Usually have 4-8 valence electrons
Most corrode easily	
Usually high melting point (usually solid at room temperature except for mercury)	

Difference between Carbon steel and alloy steel

Carbon Steel	Alloy Steel
1 Melting point is low	Melting point is high
2 Easy to work	Hard to work
3 Uniform hardness is not obtained	Uniform hardness is achieved
4 Cutting tool blunt at high temperature during operation	Cutting tool does not blunt at high temperature during operation
5 Rust easily	Does not rust easily
6 Corrosion in acid	Does not corrosion in acid
7 Magnetically attracted	Not attractive by magnetism
8 Low cost	High cost

Material science - Properties and uses of rubber, timber and insulating materials

Properties and uses of rubber

Rubber

Rubber is an elastic material. It can be classified into

- Natural rubber
- Hard rubber
- Synthetic rubber

Natural rubber

It is obtained from the secretion of plants. It softens on heating, becomes sticky at 30°C and hardens at about 5°C.

Sulphur is added to rubber and the mixture is heated. This process is called vulcanising. By this process, stronger, harder and more rigid rubber is obtained. Further, it becomes less sensitive to changes of temperature and does not dissolve in organic solvents. Its oxidation is also minimised by increasing its weathering properties.

By adding carbon black, oil wax, etc, the deformation properties are minimised. Rubber is moisture-repellent and possesses good electrical properties. The main disadvantages of the rubber are as given under.

- Low resistance to petroleum oils.
- Cannot be exposed to sunlight.

- Cannot be used for high-voltage insulation.
- Low operating temperature (as it becomes brittle and develops cracks at a temperature of 60°C)
- Sulphur in rubber reacts with copper. Hence, copper wires are to be tinned.

Hard rubber

By increasing the sulphur content and prolonged vulcanization, a rigid rubber product called hard rubber or ebonite is obtained. It possesses good electrical and mechanical properties.

Uses

It is used for battery containers, panel boards, bushing, ebonite tubes, etc.

Synthetic rubber

This is similar to natural rubber and is obtained from thermoplastic vinyl high polymers. Some of the important synthetic rubbers are:

- Nitrile butadiene rubber
- Butyl rubber
- Hypalon rubber
- Neoprene rubber
- Silicon rubber

SI.No.	Name	Properties	Uses
1	Nitrile butadiene rubber	Good resilience, wear resistance, flexibility at low temperature, resistance to ageing, oxidation, low tensile strength, high thermal conductivity, low hygroscopicity	Automobile tyre inner tubes.
2	Butyl	It is attacked by petroleum oils, gases and alcoholic solvents. It has thermal and oxidation stability and high resistance to ozone.	Used as insulation in hot and wet conditions, used as tapes in repair work.
3	Hypalon rubber	Resistance to deterioration when exposed to sunlight and temperature (up to 150°C).	Used in jacketing of electric wires and cables
4	Neoprene rubber	Better resistance to ageing, oxidation and gas diffusion, better thermal conductivity and flame resistance, poor mechanical properties.	Used for wire insulation and cable sheathing.
5	Silicon	High operating temperature (200°C) flexibility, moisture and corrosion resistance, resistance to oxidation, ozone, arcing, good insulating properties and thermal conductivity. It is a good insulator.	Insulation for power cables and control wires of blast furnace coke ovens, steel mills and nuclear power stations high frequency generators, boiler, airport lighting cranes.

Properties and uses of timber

General properties

Timber should have the following properties

- Straight fibres.
- Silky lustre when planed.
- Uniform colour.
- Regular annual rings.
- Heaviness.
- Firm adhesion of fiber and compact modular rays.
- Sweet smell.
- It should be free from loose or dead knots and shakes.
- The surface should not clog the teeth of the saw on cutting but should remain bright.

Classification

- Timbers are classified as
 - a Softwood
 - b hardwood

Softwood timber

- Usually all trees with needle leaves of softwood and those with broad leaves are of hard-wood.
- The wood contains resins and turpentine.
- The wood has a fragrant smell.
- Fibres are straight.
- Texture is soft and regular.
- Tough for resisting tensile stresses.
- Weak across the fibres.
- Annual rings are distinct, having one side soft, porous and light coloured. The other side is dense and dark.
- The general colour of the wood is pale tinted or light such as pine spruce, fir, ash, kail, deodar etc.

Properties of hardwood

- The wood generally contains a large percentage of acid.
- It is brightly coloured.
- Annual rings are not distinct.
- It is difficult and hard to work with.
- It resists shearing stress.
- Fibre are overlapped.
- The general colour is dark brown such as oak, walnut, teak, mahogany, sishim, babul, sal etc.

Uses

Soft timber

- Because of its cheapness it is used for low grade furniture, doors and windows for cheap type of houses.
- Used as fuel.
- Some timbers are used for baskets and mat making.
- The bark is used as garment in some places.

Hard timber

- Used for high quality furniture such as chairs, tables, sofas, dewans, beds, etc.
- Used for door, window frames for high quality houses as they can take good polish and painting finish.
- Used for manufacturing katha.

Wood as an electrical insulator

Wood is impregnated with oil or other substance, for use as insulator.

Example

It is used in electrical machine windings, as slot wedges.

Insulating materials

Description

These are the materials which offer very high resistance to the flow of current and make current flow very negligible or nil. These materials have very high resistance - usually of many megohms (1 Megohm = 10^6 ohms) are centimetre cubed. The insulators should also possess high dielectric strength. This means that the insulating material should not break down or puncture even on application of a high voltage (or high electrical pressure) to a given thickness.

Properties of insulators

The main requirements of a good insulating material are:

- High specific resistance (many megohms/cm cube) to reduce the leakage currents to a negligible value.
- Good dielectric strength i.e. high value of breakdown voltage (expressed in kilovolts per mm).
- Good mechanical strength, in tension or compression (It must resist the stresses set up during erection and under working conditions.)
- Little deterioration with rise in temperature (The insulating properties should not change much with the rise in temperature i.e. when electrical machines are loaded.)
- Non-absorption of moisture, when exposed to damp atmospheric condition. (The insulating properties, specially specific resistance and dielectric strength decrease considerably with the absorption of even a slight amount of moisture.)

Products and insulators

Insulators	Uses in electric field
1 Mica	In elements or winding (Slot insulation)
2 Rubber	Insulation in wires
3 Dry cotton	Winding
4 Varnish	Winding
5 Asbestos	In the bottom of irons and kettles, etc.
6 Gutta percha	Submarine cables
7 Porcelain	Overhead lines insulators
8 Glass	-do-
9 Wood dry	Cross arms in overhead lines
10 Plastic	Wires insulation or switches body
11 Ebonite	Bobbin of transformer
12 Fibre	Bobbin making and winding insulation
13 Empire cloth	Winding insulation
14 Leatheroid paper	-do-
15 Milinex paper	-do-
16 P.V.C.	Wire insulation
17 Bakelite	Switch etc. making, for insulation
18 Shellac	-do-
19 Slate	Making panel board
20 Paraffin Wax	Sealing

Mass, Weight, Volume and Density - Mass, volume, density, weight and specific gravity

Mass

Mass of a body is the quantity of matter contained in a body. The unit of mass in F.P.S system is pound (lb), in C.G.S. system gram (gr) and in M.K.S and S.I systems kilogram (kg). 1 ton which is 1000 kg is also used sometimes. The conversion factor is 1000. Three decimal places are shifted during conversion. E.g. 1 ton = 1000 kg 1g = 1000mg.

m - mass of a body

g - acceleration due to gravity in metre/sec² = 9.81 m/sec²

V - volume of the body

ρ - density (pronounced as 'rho')

W or FG - weight or weight force

Mass (Fig 1)

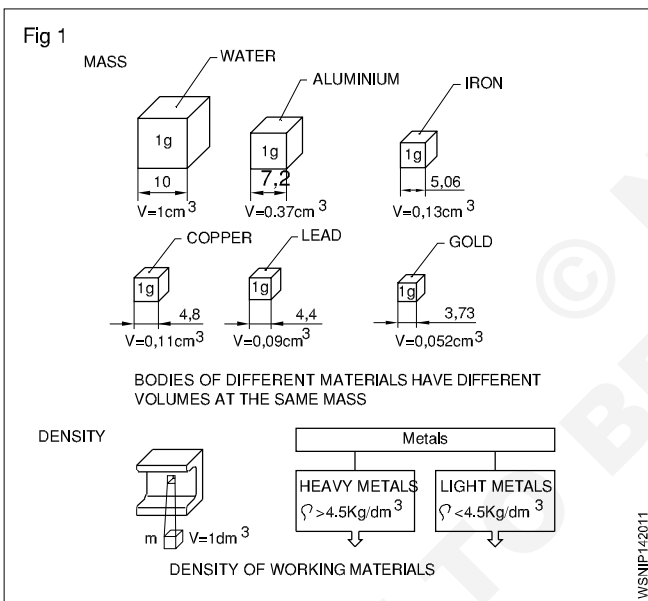

Density

Density is the mass of a body per unit volume. Hence its unit will be gr/cm³ or kg/dm³ or ton/m³.

$$\text{Density} = \frac{\text{mass}}{\text{volume}} = \frac{m}{v} = \rho$$

Weight (Fig 2)

Weight is the force with which a body is attracted by the earth towards its centre. It is the product of the mass of the body and the acceleration due to gravity. The weight of a body depends upon its location.

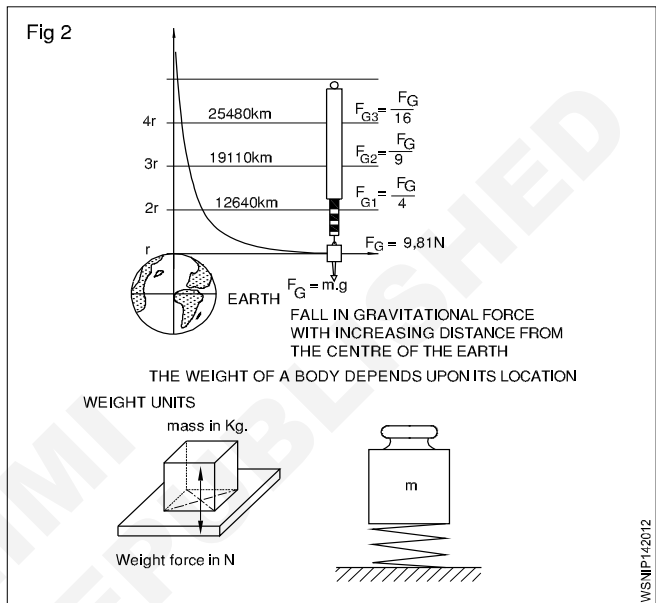

weight = W or FG = mass x gravitational force = m x g

System	Absolute unit	Derived unit	Conversion
F.P.S. system	1 poundal	1 Lb wt	32.2 poundals (1 lb x 1 ft/sec ² = 1 pound)
C.G.S. system	1 dyne 1 gr x 1 cm/sec ²	1 Gr.wt	981 dynes
M.K.S.	Newton	1 kg.wt	1 Newton =
S.I. system	Newton	Newton	1 kg x 1 m/sec ²

1 kg.wt = 9.81 Newton (approximately 10N) **1 Newton = 10⁵ dynes.**

Difference between mass and weight

S. No	Mass	Weight
1	Mass is the quantity of matter in a body (ie) measurement of matter in a body	Weight is measure of amount of force acting on mass due to acceleration due to gravity
2	It does not depend on the position or space	It depends on the position, location and space
3	Mass of an object will not be zero	Weight of an object will be zero if gravity is absent
4	It is measured using by physical balance	It is measured using by spring balance
5	It is a scalar quantity	It is a vector quantity
6	When immersed in water mass does not change	When immersed in water weight will change
7	The unit is in grams and kilogram	The unit is in kilogram weight, a unit of force

Mass and weight are different quantities.
Mass of a body is equal to volume x density.
Weight force is equal to mass x acceleration due to gravity.

Weight , Density and Specific gravity

It is now seen that the mass of a substance is measured by its weight only without any reference to volume. But if equal weights of lead & aluminium, are compared the volume of lead is much smaller than volume of aluminium. So we can now say that lead is more dense than aluminium, .i.e In other words the density of lead is greater than aluminium. (Fig 3 & 4)

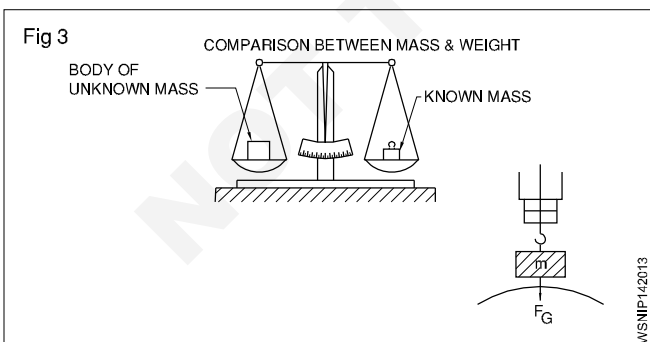

The relation of mass and volume is called density.

The density expresses the mass of volume E.g. 1 dm³ of water has the mass of 1kg - thus the density of 1kg/dm³ (Fig 2)

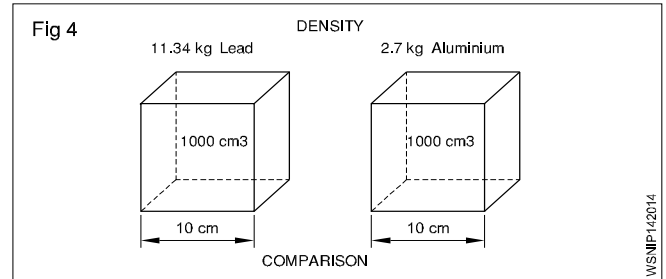

Unit

The density is measured as below

MKS/SI= Kg/m³, CGS = 1 gm/cm³ FPS = lbs/c ft

Solids	gm/cc	Liquids	gm/cc
1 Aluminium	2.7	Water	1.00
2 Lead	11.34	Petrol	0.71
3 Cast iron	6.8 to 7.8	Oxygen	1.43
4 Steel	7.75 to 8.05	Diesel Oil	0.83

The specific gravity of a substance is also called its relative density.

Formula

Specific gravity
 (or) Relative density = $\frac{\text{Density of the substance}}{\text{Density of the water at } 4^{\circ}\text{C}}$

= $\frac{\text{Mass of any volume of a substance}}{\text{Mass of an equal volume of water at } 4^{\circ}\text{C}}$

Comparison Between Density And Specific Gravity (Relative Density)

Density	Relative density or Specific gravity
Mass per unit volume of a substance is called its density Its unit is gm per cu cm; lbs per cu.ft and kg/cubic meter	The density of substance to density of water at 4°C is its relative density It has no unit of measurement simply expressed in a number
Density = $\frac{\text{Mass}}{\text{Volume}}$	Relative density = $\frac{\text{Density of the substance}}{\text{Density of water at } 4^{\circ}\text{C}}$

Solids	Sp.gy	Liquids	Sp.gy
1 Aluminium	2.72	Petrol	0.71
2 Lead	11.34	Battery acid	1.2 to 1.23
3 Cast iron	6.8 to 7.8	Water	1.00
4 Steel	7.82	Diesel Oil	0.83

From the above table, we can calculate the weight of any given volume of a substance (say Diesel oil) in any units provided we know the specific gravity of the substance. Also vice-versa for volume of density is known.

Mensuration - Area and perimeter of square, rectangle and parallelogram

In Engineering field, an Engineer has to estimate the material, manpower, machinery, etc. required to prepare the geometrical objects. Hence we must be very conversant with all relevant formulae connected with geometrical objects.

- Length - l unit
- Breadth or width - b unit
- Diagonal - d unit
- Diameter - d unit

- Radius - r unit
- Semi perimeter - S unit
- Perimeter - P unit
- Circumference - C unit
- Area - A unit²
- Total surface area - T.S.A unit²
- Lateral surface area - L.S.A unit²
- Volume - V unit³

Square

This is also a four sided figure, opposite sides are parallel. All the four sides are equal. Angle between adjacent side are 90°.

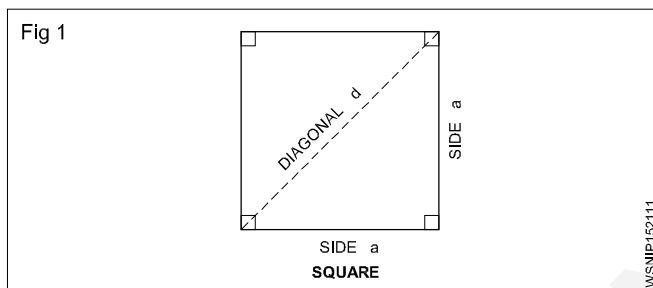

$$A = a^2 \text{ (or) unit}^2$$

$$P = 4a \text{ unit}$$

$$d = \sqrt{2} a \text{ unit}$$

$$a = \frac{d}{\sqrt{2}} \text{ unit where } \sqrt{2} = 1.414$$

Find the area of a brass sheet in the form of a square whose perimeter is 31.2 cm.

$$\text{Perimeter}(P) = 4a = 31.2 \text{ cm}$$

$$\therefore a = \frac{31.2}{4} = 7.8 \text{ cm}$$

$$\text{Area}(A) = a^2 = 7.8 \times 7.8 = 60.84 \text{ cm}^2$$

Examples

1 Find out the circumference, diagonal and area of a square, whose side is 18 cm.

$$\begin{aligned} \text{Side of the square (a)} &= 18 \text{ cm} \\ \text{Perimeter (P)} &= 4a \\ &= 4 \times 18 = 72 \text{ cm} \\ \text{Diagonal (d)} &= \sqrt{2} \times a \\ &= \sqrt{2} \times 18 = 1.414 \times 18 \\ &= 25.45 \text{ cm} \end{aligned}$$

$$\begin{aligned} \text{Area (A)} &= a^2 \\ &= 18 \times 18 = 324 \text{ cm}^2 \end{aligned}$$

Perimeter of square = 72 cm

Diagonal = 25.45 cm ; Area = 324 cm²

2 If the diagonal of a square measure 10 cm. Find area of the square.

$$\text{Diagonal of the square (d)} = \sqrt{2} a = 10 \text{ cm}$$

$$\text{Side (a)} = \frac{d}{\sqrt{2}}$$

$$\begin{aligned} \text{Area (a}^2) &= \frac{d}{\sqrt{2}} \times \frac{d}{\sqrt{2}} = \frac{d^2}{2} \\ &= \frac{10^2}{2} = \frac{100}{2} \\ &= 50 \text{ cm}^2 \end{aligned}$$

Area of the square = 50 cm²

3 The perimeter of one square is 748 cm and that of Another is 336 cm. Find the total area of the two squares.

$$\text{Side of the square (a)} = \frac{\text{Perimeter}}{4}$$

1st square

$$\text{Side (a)} = \frac{\text{Perimeter of 1}^{\text{st}} \text{ square}}{4}$$

$$= \frac{748}{4} = 187 \text{ cm}$$

$$\begin{aligned} \text{Area (A)} &= a^2 \\ &= 187 \times 187 \\ &= 34,969 \text{ cm}^2 \end{aligned}$$

2nd square

$$\text{Side (a)} = \frac{\text{Perimeter of 2}^{\text{nd}} \text{ square}}{4}$$

$$= \frac{336}{4} = 84 \text{ cm}$$

$$\begin{aligned} \text{Area (A)} &= a^2 \\ &= 84 \times 84 \\ &= 7,056 \text{ cm}^2 \end{aligned}$$

$$\begin{aligned} \text{Total area of two squares} &= 34,969 + 7,056 \\ &= 42,025 \text{ cm}^2 \end{aligned}$$

Assignment

- Find the Area, Perimeter and diagonal of a square steel plate whose side measures 28.1 cm.
- Find the area of a square whose diagonal is equal to 8.5 cm.
- Find the area of the square if the side of the square is 28 cm.
- Find its side if the area of the square field is 169 m².
- Find the area of the square if the diagonal of the square is 20 cm.
- Find the perimeter of a square whose diagonal is 144 m.
- Find the area if the perimeter of a square plot is 48 m.

Rectangle

This is a four sided figure. Opposite sides are parallel. Angles between adjacent sides are 90°.

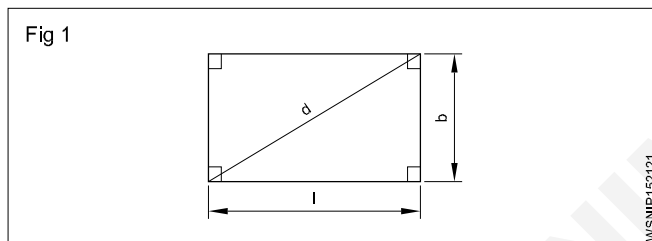

$$A = \text{Area} = \text{length} \times \text{breadth} = l \cdot b \cdot \text{unit}^2$$

$$P = \text{Perimeter} = 2(l + b) \text{ unit}$$

$$\text{Diagonal} = \sqrt{l^2 + b^2} \text{ unit}$$

Examples

- Find the Area, Perimeter and diagonal of a rectangle whose length and breadth are 144 mm and 60 mm respectively.

$$\begin{aligned} \text{Area} = A &= l \times b \text{ unit}^2 \\ &= 144 \times 60 = 8640 \text{ mm}^2 \end{aligned}$$

$$\begin{aligned} \text{Perimeter} = P &= 2(l + b) \text{ unit} \\ &= 2(144 + 60) \\ &= 2 \times 204 = 408 \text{ mm} \end{aligned}$$

$$\begin{aligned} \text{Diagonal} = d &= \sqrt{l^2 + b^2} \text{ unit} \\ &= \sqrt{144^2 + 60^2} \\ &= \sqrt{20736 + 3600} \\ &= \sqrt{24336} = 156 \text{ mm} \end{aligned}$$

- The perimeter of a rectangle is equal to 42 cm. If its breadth is 9 cm. Find the length of the rectangle.

$$\text{Perimeter} = 42 \text{ cm}$$

$$\text{Breath} = 9 \text{ cm}$$

$$\text{Length} = ?$$

$$\text{Perimeter} = P = 2(l + b)$$

$$2(l + 9) = 42$$

$$l + 9 = 42 \div 2$$

$$l + 9 = 21$$

$$l = 21 - 9$$

$$l = 12 \text{ cm}$$

- The perimeter of a rectangle is 48 cm and its length is 4 cm more than its width. Find the length and breadth of the rectangle.

$$\text{Perimeter (P)} = 48 \text{ cm}$$

$$\text{Breath (b)} = x$$

$$\text{Length (l)} = x + 4$$

$$2(l + b) = \text{Perimeter}$$

$$2(x + 4 + x) = 48$$

$$2(2x + 4) = 48$$

$$4x + 8 = 48$$

$$4x = 48 - 8$$

$$x = \frac{40}{4} = 10$$

$$x = \text{breadth} = 10 \text{ cm}$$

$$\text{length} = x + 4 = 10 + 4 = 14 \text{ cm}$$

- 4 How many rectangular pieces of 50 cm x 20 cm can be cut out from a sheet of 1000 cm x 500 cm.

Sheet size = 1000 cm x 500 cm

Size of the rectangular piece to be cut = 50 cm x 20 cm

$$\text{No. of pieces to be cut in lengthwise} = \frac{1000}{50} = 20$$

$$\text{No. of pieces to be cut in breadthwise} = \frac{500}{20} = 25$$

$$\begin{aligned} \text{Total no. of pieces to be cut out} &= 20 \times 25 \\ &= \mathbf{500} \end{aligned}$$

- 5 The perimeter of a rectangle is 320 metre. Its sides are in the ratio of 5:3. Find the area of the rectangle.

$$\text{Ratio} = 5:3 = l : b$$

$$\text{length } l = 5x$$

$$\text{breadth } b = 3x$$

$$2(l + b) = \text{Perimeter}$$

$$2(5x + 3x) = 320$$

$$2(8x) = 320$$

$$16x = 320$$

$$x = \frac{320}{16} = 20$$

$$l = 5x = 5 \times 20 = 100 \text{ m}$$

$$b = 3x = 3 \times 20 = 60 \text{ m}$$

$$\begin{aligned} \text{Area} &= l \times b \quad (\text{length} = 100\text{m, breadth} = 60\text{m}) \\ &= 100 \times 60 \end{aligned}$$

$$\text{Area} = 6000 \text{ m}^2$$

Assignment

- Find the area of a rectangular plot whose sides are 24 metres and 20 metres respectively. Also find the perimeter of the plot.
- How many rectangular pieces of 5 cm x 4 cm will you get out of 65 cm x 30 cm brass sheet?
- Find its breadth and area if the perimeter of a rectangle is 400 metre and its length is 140 m.
- Find its area, if the opposite sides of a rectangle are 64 cm and 25 cm respectively.
- What is the width of the rectangle if a rectangle has an area of 224 cm² and length 16 cm.
- What is the length of the diagonal of a rectangle with sides 16 cm and 12 cm?
- Find the area of the rectangle if the perimeter of the rectangle is 100 cm and the ratio of its length and breadth is 3:2.

Parallelogram

This is also a four sided figure, opposite side being parallel to each other.

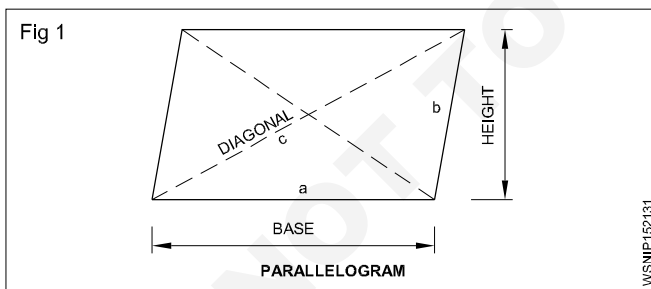

Area of parallelogram = base x height

$$\text{or } = 2x\sqrt{s(s-a)(s-b)(s-c)}$$

Where

$$s = \frac{a+b+c}{2}$$

a and b are adjacent sides.

$$P = 2(a+b)$$

Examples

- 1 The base and height of a parallelogram are 7.1 cm and 2.85 cm. Calculate its area.

$$\begin{aligned} A &= \text{base} \times \text{height units}^2 \\ &= 7.1 \times 2.85 \\ &= \mathbf{20.235 \text{ cm}^2} \end{aligned}$$

- 2 Find the height of a parallelogram whose area is 20 cm² and base is 10 cm.

$$\begin{aligned} A &= \text{base} \times \text{height units}^2 \\ h &= \frac{\text{area}}{\text{base}} \\ &= \frac{20}{10} \\ &= \mathbf{2 \text{ cm}} \end{aligned}$$

3. Two sides of a parallelogram are 12 cm and 8 cm. The diagonal is 10 cm long. Find the area of the parallelogram.

$$\begin{aligned} \text{Area } A &= 2x\sqrt{s(s-a)(s-b)(s-c)} \text{ units}^2 \\ s &= \frac{a+b+c}{2} \\ &= \frac{12+8+10}{2} \\ &= \frac{30}{2} \\ &= 15 \end{aligned}$$

$$\begin{aligned} A &= 2x\sqrt{15(15-12)(15-8)(15-10)} \\ &= 2x\sqrt{15 \times 3 \times 7 \times 5} \\ &= 2x\sqrt{1575} \\ &= 2 \times 39.686 \\ \text{Area } A &= 79.37 \text{ cm}^2 \end{aligned}$$

Assignment

- 1 Find the area of a parallelogram, if its base and height are 8.1 cm and 30.8 cm respectively.
- 2 Find the area of a parallelogram, if the sides of a field in the shape of parallelogram are 12 m and 17 m and one of the diagonal is 25 m.
- 3 Find the base of a parallelogram whose height is 12 cm and area is 120 cm².
- 4 Find the height of a parallelogram whose base is 40 cm and area is 320 cm².
- 5 Find the area of the land if the sides of a land in the shape of a parallelogram are 24 m and 28 m respectively and one of the diagonal is 30 m.
- 6 What is the perimeter of parallelogram if base is 10 cm and other side is 5 cm?
- 7 Find the area of parallelogram if its base and height are 25 cm and 12 cm.
- 8 Find the base of a parallelogram if height is 15 cm and area is 150 cm².
- 9 Find the height of a parallelogram if base is 80 cm and area is 640 cm².
- 10 Find the area of parallelogram if its base and height are 15 cm and 8 cm.
- 11 Calculate the perimeter and area of parallelogram if base, height are 12.7 cm, 5.5 cm and other side is 6.5 cm.
- 12 Find the height of parallelogram if the area is 20 cm² and base is 10 cm.

Mensuration - Area and perimeter of triangles

Triangles

Tri means three. Hence tri- angle means three angled figure. For construction of three angled figure, there should be three sides. Hence triangle means three sided figure. Sum of the three angles of any triangle = 180°.

i Any triangle.

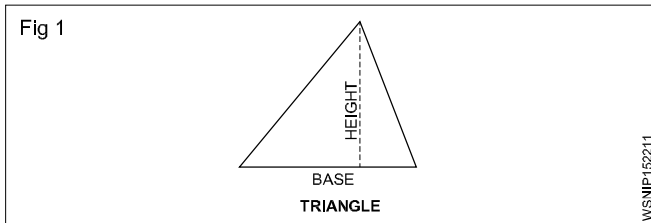

Area of any triangle = $\frac{1}{2}$ x Base x Height unit²

ii Isosceles Triangle

In this triangle two of its sides are equal.

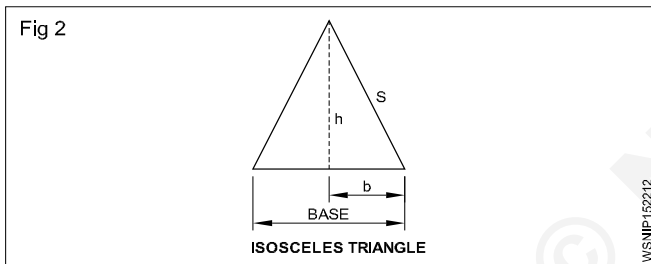

Area of isosceles triangle = $\frac{1}{2}$ x Base x Height

Where

base = 2.b

s = One of equal sides (or) Slant height

h = Height = $\sqrt{s^2 - b^2}$

Area of isosceles triangle = $\frac{1}{2}$ x 2b x $\sqrt{s^2 - b^2}$

= b . $\sqrt{s^2 - b^2}$ unit²

(Where b= half of base)

(or) Area of Isosceles triangle = $\frac{1}{4}$ b $\sqrt{4a^2 - b^2}$ unit²

a = Equal sides

b = Base

iii Equilateral triangle

In this triangle all the three sides are equal. Hence angle between adjacent sides is 60° (Three angles total = 180°);

angle between sides = $\frac{180}{3} = 60^\circ$

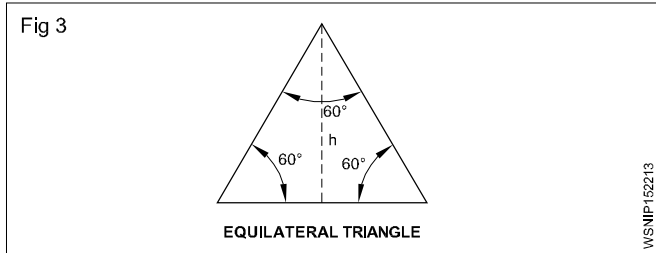

Area of equilateral triangle = $\frac{\sqrt{3}}{4}$ x side²
 = $\frac{\sqrt{3}}{4}$ x a² unit²

Where $\sqrt{3} = 1.732$
 Perimeter P = 3a unit

P = $\frac{\sqrt{3}}{2}$ a unit

iv Scalene triangle

In this triangle the sides are not equal. Angles between the sides, are also not equal. we may also call this triangle as irregular triangle.

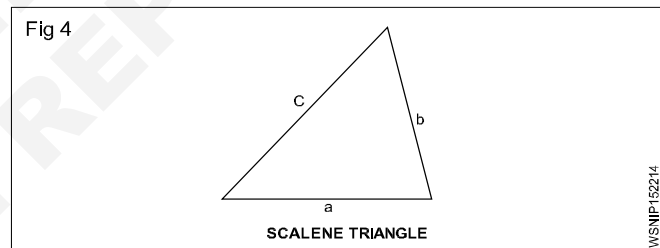

Area of triangle = $\sqrt{s(s-a)(s-b)(s-c)}$ unit²

where

a,b,c are sides of triangle

s = Semi perimeter = $\frac{a+b+c}{2}$ unit

v Right angled triangle

In this triangle, angle between one of two adjacent sides is 90°. Right angle means 90°. That's why right angled triangle means, one of the angles of this triangle is definitely 90°.

Area of right angled triangle

= $\frac{1}{2}$ x Base x Height

= $\frac{1}{2}$ bh unit²

Hypotenuse = $\sqrt{\text{Base}^2 + \text{Height}^2}$

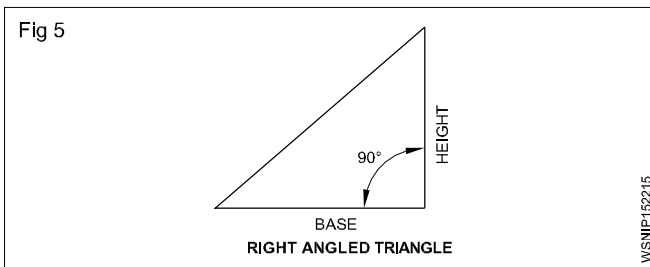

Where hypotenuse means, the diagonal or largest length of the side of right angled triangle.

Examples

- 1 Calculate its area if the base and height of a Right angled triangle are 10 cm and 3.5 cm respectively.

$$\begin{aligned} \text{Base (b)} &= 10 \text{ cm} \\ \text{Height (h)} &= 3.5 \text{ cm} \\ \text{Area (A)} &= ? \\ A &= \frac{1}{2} \times b \times h \\ &= \frac{1}{2} \times 10 \times 3.5 \\ &= \mathbf{17.5 \text{ cm}^2} \end{aligned}$$

- 2 Calculate the base of a triangle having an area of 15 cm² and height is 3.5 cm.

$$\begin{aligned} \text{Area (A)} &= 15 \text{ cm}^2 \\ \text{Height (h)} &= 3.5 \text{ cm} \\ \text{Base (b)} &= ? \\ \frac{1}{2} \times b \times h &= A \\ \frac{1}{2} \times b \times 3.5 &= 15 \\ \mathbf{b} &= \frac{15 \times 2}{3.5} \\ &= \mathbf{8.57 \text{ cm}} \end{aligned}$$

- 3 Calculate the height of a triangle whose area is 60 cm² and base is 10 cm.

$$\begin{aligned} \text{Area (A)} &= 60 \text{ cm}^2 \\ \text{Base (b)} &= 10 \text{ cm} \\ \text{Height (h)} &= ? \\ \frac{1}{2} \times b \times h &= A \\ \frac{1}{2} \times 10 \times h &= 60 \\ h &= \frac{60 \times 2}{10} \\ \mathbf{\text{height } h} &= \mathbf{12 \text{ cm}} \end{aligned}$$

- 4 Find the area of an isosceles triangle whose base is 6 cm long and each of the other two sides 5 cm long.

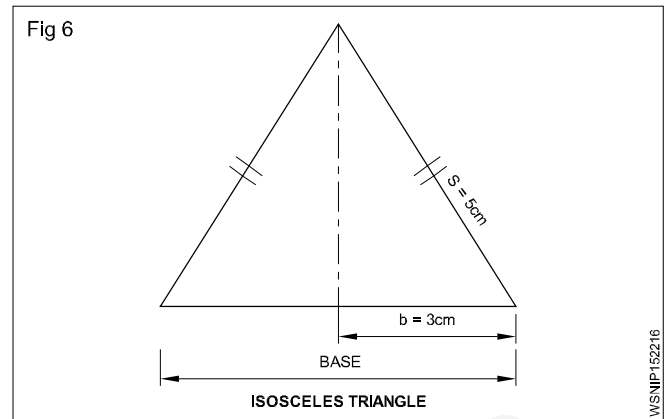

$$\text{Base (b)} = 6 \text{ cm} = \frac{6}{2} = 3 \text{ cm}$$

$$\text{Equal sides or slant height 's'} = 5 \text{ cm}$$

$$\text{Area (A)} = ?$$

$$A = b \times \sqrt{s^2 - b^2}$$

$$= 3 \times \sqrt{5^2 - 3^2}$$

$$= 3 \times \sqrt{25 - 9}$$

$$= 3 \times \sqrt{16}$$

$$= 3 \times 4$$

$$= 12 \text{ cm}^2$$

or

$$A = \frac{1}{4} b \sqrt{4a^2 - b^2}$$

$$= \frac{1}{4} \times 6 \sqrt{4 \times 5^2 - 6^2}$$

$$= \frac{1}{4} \times 6 \times 8$$

$$= \mathbf{12 \text{ cm}^2}$$

- 5 Find its height if an isosceles triangle has base of 200 mm and its area is 2000 mm².

$$\text{Base} = 200 \text{ mm}$$

$$\text{Area} = 2000 \text{ mm}^2$$

$$h = ?$$

$$\frac{1}{2} \times b \times h = A$$

$$\frac{1}{2} \times 200 \times h = 2000$$

$$h = \frac{2000 \times 2}{200} = \mathbf{20 \text{ mm}}$$

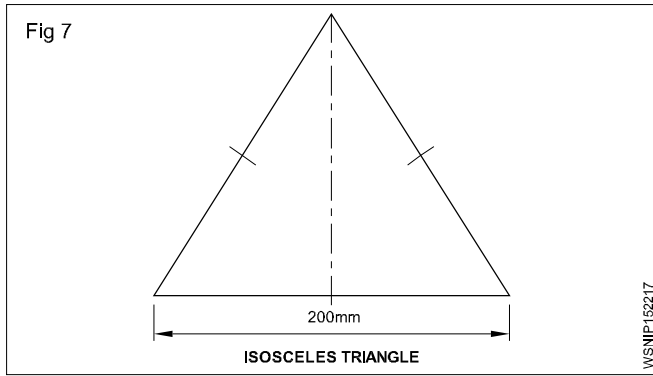

- 6 Find the area of an equilateral triangle whose side is 5 cm.

$$\begin{aligned} \text{Area} &= \frac{\sqrt{3}}{4} a^2 \text{ unit}^2 \\ &= \frac{1.732}{4} \times 5 \times 5 \\ &= \mathbf{10.825 \text{ cm}^2} \end{aligned}$$

- 7 Calculate its perimeter if one side of an equilateral triangle is 55 mm long.

$$\begin{aligned} \text{Side} &= 55 \text{ mm} \\ \text{Perimeter (P)} &= ? \\ P &= 3a \text{ unit} \\ &= 3 \times 55 \\ &= \mathbf{165 \text{ mm}} \end{aligned}$$

- 8 Find the area of the triangle having its sides are 9cm, 10cm and 12 cm.

$$\begin{aligned} \text{Semi Perimeter} &= \frac{a+b+c}{2} \text{ unit} \\ &= \frac{9+10+12}{2} = \frac{31}{2} \\ &= 15.5 \text{ cm} \\ \text{Area A} &= \sqrt{s(s-a)(s-b)(s-c)} \text{ unit}^2 \\ &= \sqrt{15.5(15.5-9)(15.5-10)(15.5-12)} \\ &= \sqrt{15.5 \times 6.5 \times 5.5 \times 3.5} \\ &= \sqrt{1939.4375} \\ &= \mathbf{44.03 \text{ cm}^2} \end{aligned}$$

- 9 Find the cost of polishing on both sides of a triangular metal plate has sides 60 cm, 50 cm and 20 cm at the rate of Rs. 1.35 per 100 cm²

$$\text{Semi Perimeter} = \frac{a+b+c}{2} \text{ unit}$$

$$= \frac{60+50+20}{2} = \frac{130}{2}$$

$$= 65 \text{ cm}$$

$$\text{Area A} = \sqrt{s(s-a)(s-b)(s-c)} \text{ unit}^2$$

$$= \sqrt{65(65-60)(65-50)(65-20)}$$

$$= \sqrt{65 \times 5 \times 15 \times 45}$$

$$= \mathbf{468.4 \text{ cm}^2}$$

$$\text{Area of polish on both sides} = 2 \times 468.4$$

$$= 936.8 \text{ cm}^2$$

$$\text{Cost of polish per } 100 \text{ cm}^2 = \text{Rs. } 1.35$$

$$\therefore \text{Cost of polish is } 936.8 \text{ cm}^2 = \frac{936.8}{100} \times 1.35$$

$$= \text{Rs. } 12.65$$

- 10 Find the area of the right angled triangle with base 20 cm and height 8 cm.

$$\text{Base } b = 20 \text{ cm}$$

$$\text{Equal sides or slant height} = 8 \text{ cm}$$

$$\text{Area (A)} = ?$$

$$\text{Area (A)} = \frac{1}{2} \times \text{base} \times \text{height unit}^2$$

$$= \frac{1}{2} \times 20 \times 8$$

$$= \mathbf{80 \text{ cm}^2}$$

- 11 Find the area of the right angled triangle if the sides containing the right angle being 10.5 cm and 8.2 cm.

$$\text{Area (A)} = \frac{1}{2} \times \text{base} \times \text{height unit}^2$$

$$= \frac{1}{2} \times 10.5 \times 8.2$$

$$= \mathbf{43.05 \text{ cm}^2}$$

- 12 Calculate the perpendicular height of the triangle if the area of the right angled triangle is 19.44 m² and its one of the adjacent side containing the right angle being 5.4 m.

$$\frac{1}{2} \times \text{base} \times \text{height unit}^2 = \text{Area}$$

$$\frac{1}{2} \times 5.4 \times h = 19.44$$

$$h = \frac{19.44 \times 2}{5.4}$$

$$= 7.2 \text{ m}$$

13 Calculate the base of a right angled triangle having an area of 12.5 cm^2 . If its height is 2.5 cm .

$$\frac{1}{2} \times \text{base} \times \text{height unit}^2 = \text{Area}$$

$$\frac{1}{2} \times b \times 2.5 = 12.5$$

$$b = \frac{12.5 \times 2}{2.5}$$

$$= 10 \text{ cm}$$

Pythagoras theorem

In a right angled triangle the area of the square drawn with the hypotenuse as the side is equal to the sum of the areas of the squares drawn with the other two sides.

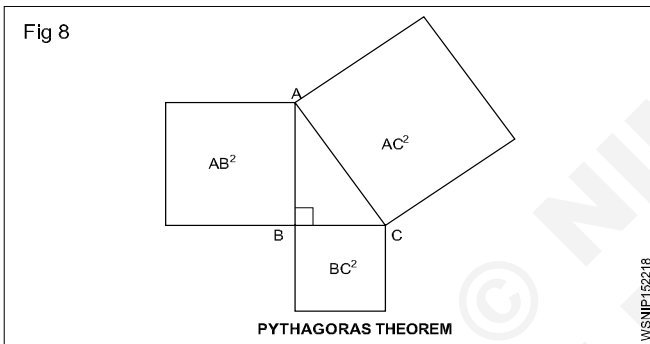

$$\angle B = 90^\circ$$

AC = Hypotenuse

AB & BC = Adjacent sides

As per pythagoras theorem,

$$AC^2 = AB^2 + BC^2$$

$$\therefore AC = \sqrt{AB^2 + BC^2}$$

1 Calculate the hypotenuse of a right angled triangle whose base is 5 cm and height is 12 cm .

As per pythagoras theorem,

$$AC^2 = AB^2 + BC^2$$

$$= 12^2 + 5^2$$

$$= 144 + 25$$

$$= 169$$

$$AC = \sqrt{169}$$

$$= 13 \text{ cm}$$

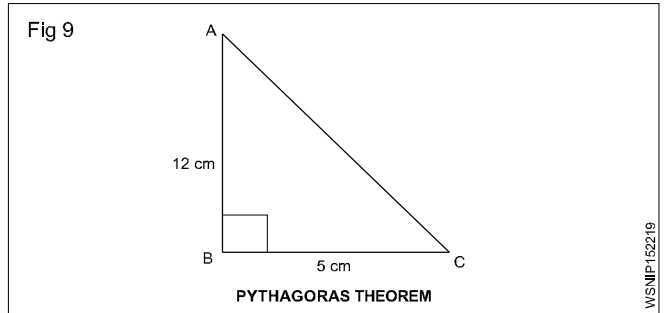

2 What is the length of the hypotenuse of a right angled triangle, when the sides containing the right angles are 10 cm and 12 cm .

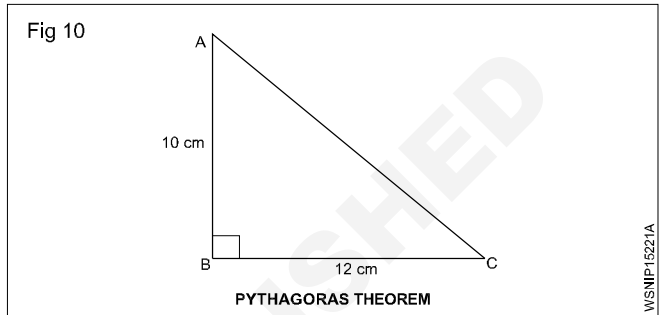

As per pythagoras theorem,

$$AC^2 = AB^2 + BC^2$$

$$= 10^2 + 12^2$$

$$= 100 + 144$$

$$= 244$$

$$AC = \sqrt{244}$$

$$= 15.62 \text{ cm}$$

3 Find the height of a right angled triangle whose base is 15 cm and hypotenuse is 21 cm .

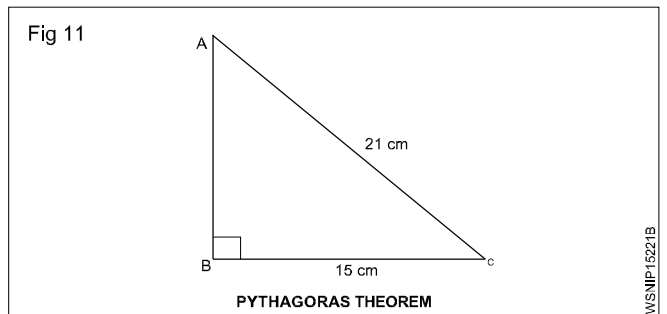

As per pythagoras theorem,

$$AB^2 + BC^2 = AC^2$$

$$AB^2 + 15^2 = 21^2$$

$$AB^2 = 441 - 225$$

$$= 216$$

$$AB = \sqrt{216}$$

$$= 14.7 \text{ cm}$$

Levers & Simple machines - Lever and its types

Lever

A lever is a rigid rod which rotates about a fixed point called the fulcrum.

E.g. : Cutting plier, A pair of scissors, Crow bar, Beam balance, Hand pump.

The distance of the load from the fulcrum is called the load arm. The distance of the effort from the fulcrum is called the effort arm.

Principle of Lever

- All levers are functioning in the following principle

$$\text{Load} \times \text{Load arm} = \text{Effort} \times \text{Effort arm}$$

Classification of lever

- 1 Straight lever
- 2 Curved lever

1 Straight lever

There are three types :

- 1 First order lever
- 2 Second order lever
- 3 Third order lever

First order lever

In this type the fulcrum lies between the load and the effort.

E.g : A pair of scissors, See-saw, Crow bar, Beam balance, Hand pump, etc.,

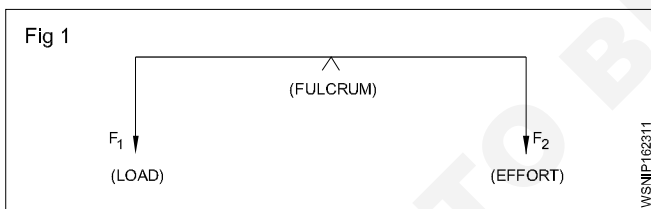

In this type of lever the mechanical advantage will be equal or less than or greater than 1 ($M.A < = > 1$)

Second order lever

In this type, the load lies between the fulcrum and the effort.

E.g : Nut cracker, Wheel barrow, Paper sheet cutter, Bottle openers, Lime squeezer, etc.,

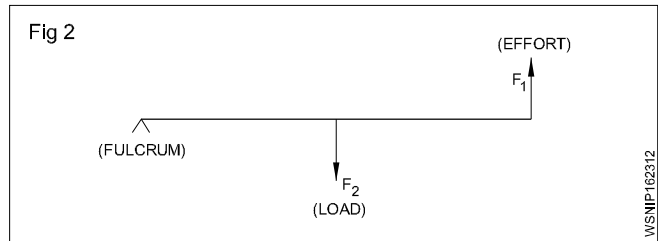

In this type of lever, the mechanical advantage will be greater than 1 ($M.A. > 1$). Less effort is used to lift more load.

Third order lever

In this type, the effort lies between the fulcrum and the load.

E.g. The human force arm, forceps, broom, fire tongs, fishing rod.

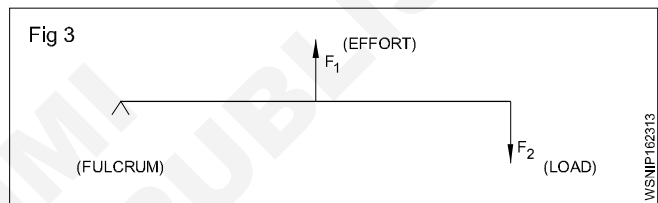

In this type of lever, the mechanical advantage will be less than 1 ($M.A < 1$) more effort is used to lift less load.

Bell cranked levers (Curved levers) (Fig 4)

In addition to the above types of levers, two rods may be joined together at an angle to increase leverage without utilising much space. Such levers are cranked levers and the special form in which included angle is 90°, is called the bell cranked lever.

E.g : Motor cycle breaks system clutch pedal.

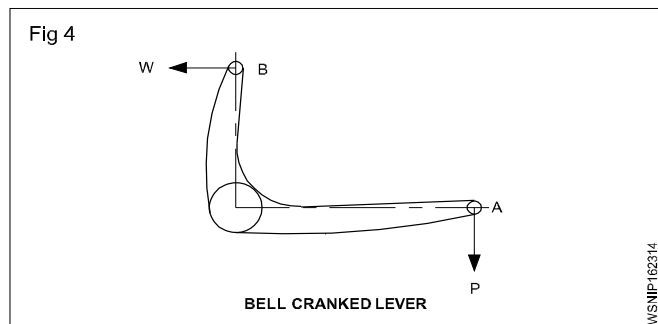
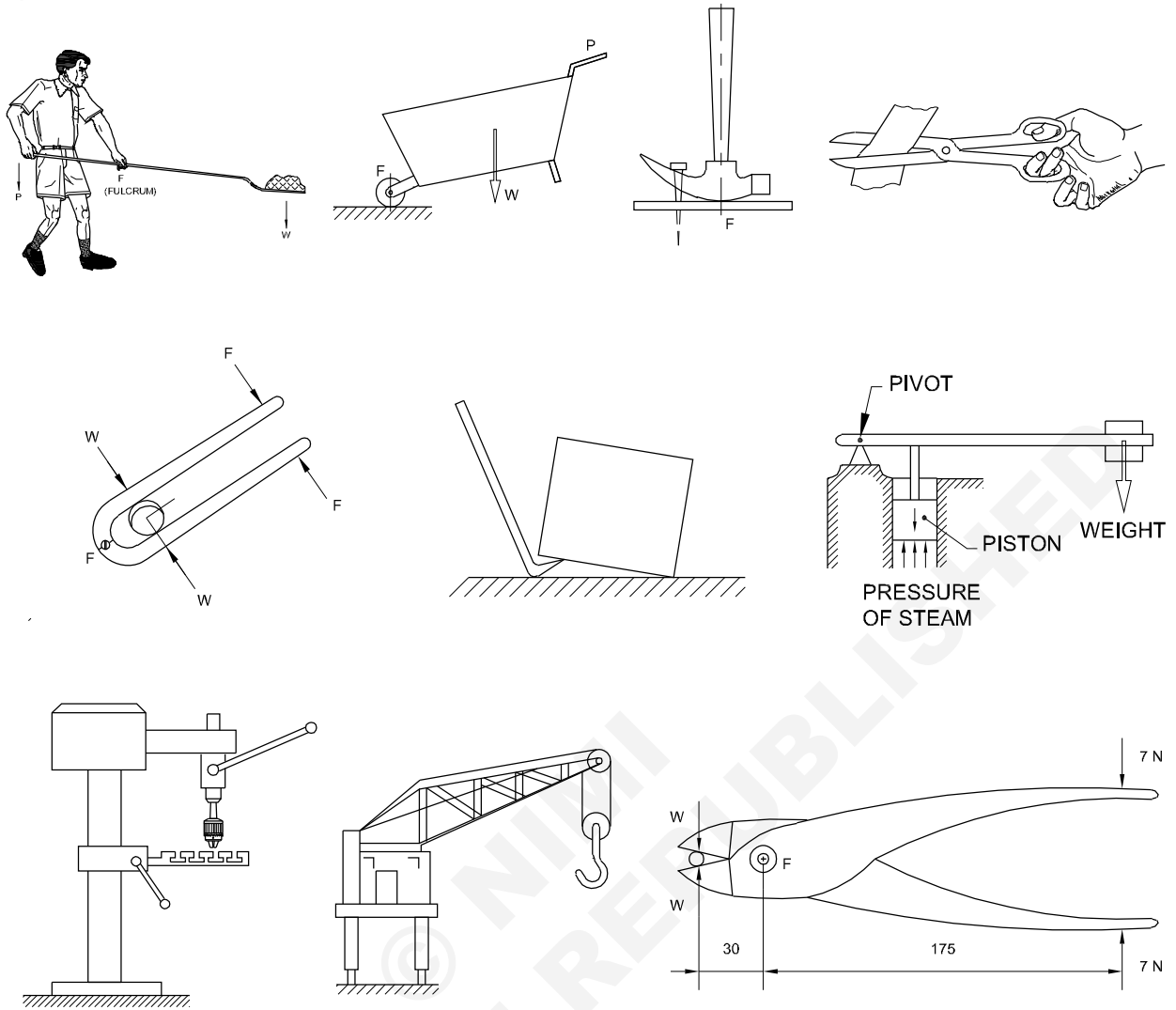

Fig 5



EXAMPLES OF SIMPLE LEVERS

W5NIP162315

Examples

- 1 Calculate the load at B, if the load is in the balance condition if a rod AB is 8 metre long and has got a weight of 10 kg at A. The fulcrum is 3 metre from B.

$$\begin{aligned}
 \text{Load} \times \text{Load arm} &= \text{Effort} \times \text{Effort arm} \\
 10 \times 5 &= P \times 3 \\
 50 &= 3P \\
 P &= 50 / 3 \\
 &= 16.67 \text{ kg}
 \end{aligned}$$

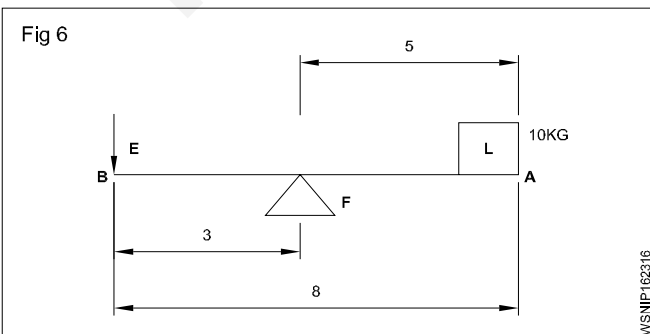

W5NIP162316

When load and effort are not given separately in the sum consider which one having more weight is as a load.

- 2 Find the effort required and mechanical advantage of the system if a weight of 3000 kg is to be lifted by a bar of length 3 metre. The load arm is 1 metre and the effort arm is 2 metre.

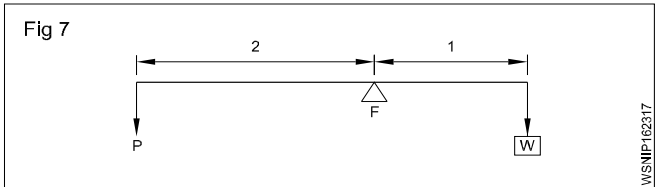

W5NIP162317

As per lever principle

$$\begin{aligned}
 \text{Load} \times \text{Load arm} &= \text{Effort} \times \text{Effort arm} \\
 3000 \times 1 &= P \times 2 \\
 3000 &= P \times 2 \\
 P &= 3000/2 \\
 &= 1500 \text{ kg}
 \end{aligned}$$

$$\text{Mechanical advantage} = \frac{\text{Load}}{\text{Effort}} = \frac{3000}{1500}$$

$$= 2$$

- 3 According to Fig. the lever has to support a 100 kg load with a 17 kg equivalent force supplied to it. Find the distance between the load and point of force.

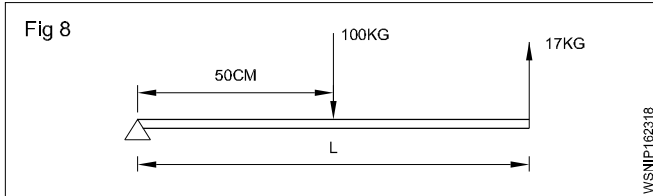

Solution.

Load = 100 kg; Effort = 17 kg.

Load arm = 50 cm

Let effort arm = x cm

As per principle of levers:

Effort x Effort arm = Load x Load arm

$$17x = 100 \times 50$$

$$x = \frac{100 \times 50}{17} = 294.1 \text{ cm}$$

$$x = 294.1 \text{ cm}$$

Distance between the load and point of force = 294.1 - 50

$$= 244.1 \text{ cm}$$

$$= 2.4410 \text{ m}$$

- 4 Find the tension of the string if an uniform bar of length 80 cm and weighing 2.1 kg is supported on a smooth peg at one end and by a vertical string at a distance of 15 cm from the other end.

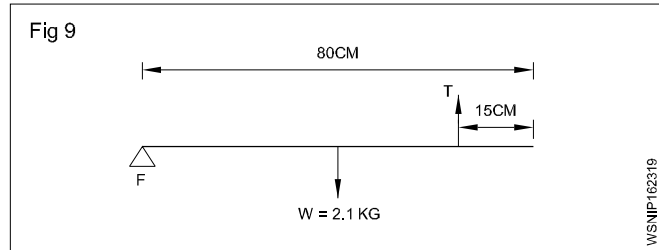

$$W = 2.1 \text{ kg}$$

$$\text{Tension} = T \text{ kg}$$

$$P \times dp = 2.1 \times dv$$

$$T \text{ kg} \times (80 - 15) \text{ cm} = 2.1 \text{ kg} \times \frac{80}{2} \text{ cm}$$

$$T \times 65 = 2.1 \times 40$$

$$T = \frac{2.1 \times 40}{65} \text{ kg.}$$

$$\text{Tension} = 1.292 \text{ kg}$$

- 5 In the figure given below in bell cranked lever AFB on perpendicular AF the force P is 40 kg. Weight W is on perpendicular FB. Find the measure of W.

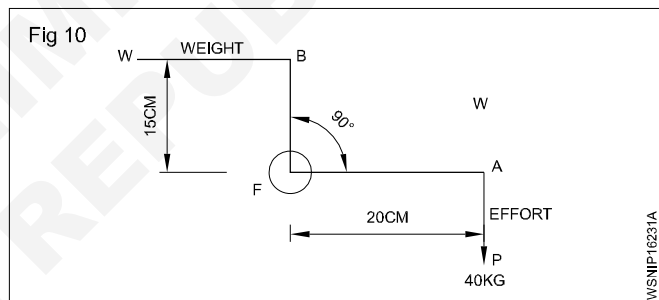

Solution. By principle of momentum

$$P \times AF = W \times BF$$

$$40 \times 20 = W \times 15$$

$$W = \frac{40 \times 20}{15} = \frac{160}{3} = 53.3 \text{ kg.}$$

Assignment

- 1
 - a Which order belongs to forearm of a human body.
 - b Which order belongs to a pair of sugar tongs.
 - c Which order belongs to carburetor Throttle Valve.
 - d Which order belongs to a common balance.
 - e Which order belongs to a pair of scissors.
 - f Which order belongs to a safety valve.
 - g Which order belongs to a Crow bar.
 - h Which order belongs to a Brake lever.
- 2
 - a What is the principle of levers?
 - b Write two examples of first order lever.
 - c Write two examples of second order lever.
 - d Write two examples of third order lever.
 - e Which order belongs to bell cranked lever.
 - f What is the Mechanical advantage?
 - g What is the Velocity ratio?
 - h What is the Efficiency?

Trigonometry - Measurement of angles

Introduction:

Trigonometry is the branch of mathematics which deals with the study of measurement and relationship of the three sides and three angles of a triangle.

Units:

Measurement of Angles

There are three systems of measuring the angle:

(i) Sexagesimal System

This is called British System. In this system, one right angle is divided into 90 equal parts which are called degrees. Each part is divided into 60 parts which are called minutes. Each minute is divided into 60 parts which are called seconds. The parts so divided respectively are called:

One degree (1°), one minute ($1'$) and one second ($1''$)

It means 1 right angle = 90° (90 degrees)

1 degree (1°) = 60' (60 minutes)

1 minute ($1'$) = 60'' (60 seconds)

In Trigonometry, mostly this system is used.

(ii) Centesimal System

This is called French System. In this system, the right angle is divided into 100 equal parts which are called grades. Each grade is divided into 100 minutes and each minute is divided into 100 seconds.

Parts so divided are respectively called:

One grade (1 g), one minute ($1'$), one second ($1''$).

It means 1 right angle = 100 grades (100g)

1 grade (1 g) = 100 minutes ($100'$)

1 minute ($1'$) = 100 seconds ($100''$)

$90^\circ = 100g$ (because each is a right angle)

This system is easier than Sexagesimal System. But to use this system many other systems will have to be devised that is why this system is not used.

(iii) Circular System

In this system, the unit of measuring angles is radian. It is that angle which is formed at the centre and is formed of an arc of length equal to radius in a circle.

There is one constant ratio between the circumference and dia of a circle. This is represented by π .

$$\frac{\text{Circumference}}{\text{Diameter}} = \text{constant point} = \pi$$

$$\begin{aligned} \text{Circumference} &= \pi \times \text{dia} \\ &= 2\pi r \text{ (where } r \text{ is radius of the circle)} \end{aligned}$$

$$\pi = \frac{22}{7}$$

Circumference makes an angle ($2\pi r$) = 360°

Radius of the circle makes an angle (r) = 1 Radian

$$\text{ie : } \frac{C}{r} = \frac{360^\circ}{1\text{Radian}}$$

$$\frac{2\pi r}{r} = \frac{360^\circ}{1\text{Radian}}$$

$$2\pi = \frac{360^\circ}{1\text{Radian}}$$

$$2\pi \text{ Radian} = 360^\circ$$

$$\pi \text{ Radian} = 180^\circ$$

$$1 \text{ Radian} = \frac{180^\circ}{\pi}$$

$$1^\circ = \frac{\pi}{180^\circ} \text{ Radian}$$

Examples

- 1 Convert $45^\circ 36' 20''$ into degree and decimal of degree.

$$60 \text{ seconds} = 1 \text{ minute}$$

$$20 \text{ seconds} = \frac{20}{60} = 0.333'$$

$$60 \text{ minutes} = 1 \text{ degree}$$

$$36.333 \text{ minutes} = \frac{36.333}{60} = 0.606^\circ$$

$$45^\circ 36' 20'' = 45.606^\circ$$

- 2 Convert 24.59° into degree, minute and second

$$1 \text{ degree} = 60 \text{ minutes}$$

$$0.59 \text{ degree} = 0.59 \times 60 = 35.4'$$

$$1 \text{ minute} = 60 \text{ seconds}$$

$$0.4 \text{ minute} = 60 \text{ sec} \times 0.4$$

$$= 24''$$

$$\text{Therefore } 24.59^\circ = 24^\circ 35' 24''$$

- 3 Change $50^\circ 37' 30''$ into degrees

By changing angle degrees into decimals

$$30'' = \frac{30}{60} = 0.50'$$

$$37' 30'' = 37.5'$$

$$37.5' = \frac{37.5}{60} = 0.625^\circ$$

$$50^\circ 37' 30'' = 50.625^\circ$$

4 Convert $23^{\circ}25'32''$ into radians

We know $1^{\circ} = 60' = 3600''$

Therefore $23^{\circ}25'32''$

$$= \left(23 + \frac{25}{60} + \frac{32}{3600} \right) \text{ degrees}$$

$$= \frac{82800 + 1500 + 32}{3600}$$

$$= \frac{84332}{3600}$$

But $180^{\circ} = \pi$ radians

Therefore 23.4255 degrees

$$= \frac{23.4255}{180} \pi \text{ radians}$$

$$= \frac{23.4255}{180} \times \frac{22}{7} \text{ radians}$$

$$= \mathbf{0.4089 \text{ radians}}$$

5 Convert $87^{\circ}19'57''$ into Radian.

$$19'57'' = 19' + \frac{57''}{60}$$

$$= 19' + 0.95'$$

$$= 19.95'$$

$$87^{\circ}19.95' = 87^{\circ} + \frac{19.95'}{60}$$

$$= 87^{\circ} + 0.332^{\circ} = 87.33^{\circ}$$

$$1^{\circ} = \frac{\pi}{180} \text{ radian}$$

$$87.33^{\circ} = \frac{\pi}{180} \times 87.33 \text{ radian}$$

$$= 1.524 \text{ radian}$$

6 Convert $67^{\circ}11'43''$ into Radian

$$11'43'' = 11' + \frac{43''}{60}$$

$$= 11' + 0.716'$$

$$= 11.72'$$

$$67^{\circ}11.72' = 67^{\circ} + \frac{11.72'}{60}$$

$$= 67^{\circ} + 0.195^{\circ}$$

$$= 67.2^{\circ}$$

$$1^{\circ} = \frac{\pi}{180} \text{ radian}$$

$$67.2^{\circ} = \frac{\pi}{180} \times 67.2 \text{ radian}$$

$$= 1.173 \text{ radian}$$

7 Convert $\frac{4}{7} \pi$ radian into degrees

$$1 \text{ radian} = \frac{180}{\pi} \text{ degree}$$

$$\frac{4}{7} \pi \text{ radian} = \frac{180}{\pi} \times \frac{4}{7} \pi \text{ degree}$$

$$= 102.9 \text{ degree}$$

$$= 102^{\circ} 0.9 \times 60'$$

$$= 102^{\circ} 54'$$

8 Convert 0.8357 radian into degrees

$$1 \text{ radian} = \frac{180}{\pi} \text{ degree}$$

$$0.8357 \text{ radian} = \frac{180}{\pi} \times 0.8357 \text{ degree}$$

$$= 47.88^{\circ}$$

$$= 47^{\circ} 0.88 \times 60'$$

$$= 47^{\circ} 52.80'$$

$$= 47^{\circ} 52' 0.8 \times 60''$$

$$= 47^{\circ} 52' 48''$$

9 Convert 2.752 radian into degrees

$$1 \text{ Radian} = \frac{180}{\pi} \text{ degree}$$

$$2.7520 \text{ radian} = \frac{180}{\pi} \times 2.752 \text{ degree}$$

$$= 157.7^{\circ}$$

$$= 157.7^{\circ} \times 60'$$

$$= 157^{\circ} 42'$$

10 Convert $\frac{3}{5} \pi$ radian into degrees

$$1 \text{ Radian} = \frac{180}{\pi} \text{ degree}$$

$$\frac{3}{5} \pi \text{ radian} = \frac{180}{\pi} \times \frac{3}{5} \pi \text{ degree}$$

$$= 108^{\circ}$$

Assignment

Convert into Degree

1 12 Radian

Convert into Radians

2 78°

3 $47^{\circ}20'$

4 $52^{\circ}36'45''$

5 $25^{\circ}38''$

Convert into degree, minute and seconds

6 46.723°

7 68.625°

8 0.1269 Radian

9 2.625 Radians

10 $\frac{3}{5}$ Radian

Trigonometry - Trigonometrical ratios

Dependency

The sides of a triangle bear constant ratios for a given definite value of the angle. That is, increase or decrease in the length of the sides will not affect the ratio between them unless the angle is changed. These ratios are trigonometrical ratios. For the given values of the angle a value of the ratios

$\frac{BC}{AB}, \frac{AC}{AB}, \frac{BC}{AC}, \frac{AB}{BC}, \frac{AB}{AC}$ and $\frac{AC}{BC}$ do not change even when the sides AB, BC, AC are increased to AB', BC' and AC' or decreased to AB'', BC'' and AC''.

For the angle

AC is the hypotenuse

AB is the adjacent side

BC is the opposite side.

The ratios

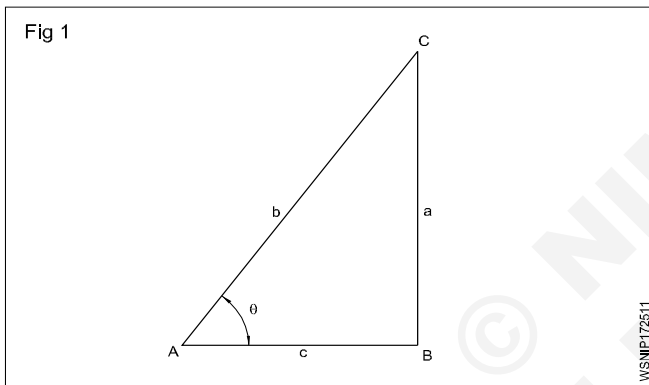

The six ratios between the sides have precise definitions.

$$\text{Sine } \theta = \frac{BC}{AC} = \frac{\text{Opposite side}}{\text{Hypotenuse}} = \text{Sin } \theta$$

$$\text{Cosine } \theta = \frac{AB}{AC} = \frac{\text{Adjacent side}}{\text{Hypotenuse}} = \text{Cos } \theta$$

$$\text{Tangent } \theta = \frac{BC}{AB} = \frac{\text{Opposite side}}{\text{Adjacent side}} = \text{Tan } \theta$$

$$\text{Cosecant } \theta = \frac{AC}{BC} = \frac{\text{Hypotenuse}}{\text{Opposite side}} = \text{Cosec } \theta$$

$$\text{Secant } \theta = \frac{AC}{AB} = \frac{\text{Hypotenuse}}{\text{Adjacent side}} = \text{Sec } \theta$$

$$\text{Cotangent } \theta = \frac{AB}{BC} = \frac{\text{Adjacent side}}{\text{Opposite side}} = \text{Cot } \theta$$

Relationship between the ratios

$$\text{Cosec } \theta = \frac{AC}{BC} = \frac{1}{\frac{BC}{AC}} = \frac{1}{\text{sin } \theta}$$

$$\text{sec } \theta = \frac{AC}{AB} = \frac{1}{\frac{AB}{AC}} = \frac{1}{\text{cos } \theta}$$

$$\text{cot } \theta = \frac{AB}{BC} = \frac{1}{\frac{BC}{AB}} = \frac{1}{\text{tan } \theta}$$

$$\text{sin } \theta = \frac{\text{side BC}}{\text{side AC}} = \frac{a}{b}$$

$$\text{cos } \theta = \frac{\text{side AB}}{\text{side AC}} = \frac{c}{b}$$

$$\frac{\text{sin } \theta}{\text{cos } \theta} = \frac{\frac{a}{b}}{\frac{c}{b}} = \frac{a}{b} \times \frac{b}{c} = \frac{a}{c}$$

$$= \frac{\text{side BC}}{\text{side AB}} = \text{tan } \theta$$

$$\text{sin } \theta = \frac{1}{\text{cosec } \theta} \text{ or } \text{cosec } \theta = \frac{1}{\text{sin } \theta} \text{ or } \text{sin } \theta \cdot \text{cosec } \theta = 1$$

$$\text{cos } \theta = \frac{1}{\text{sec } \theta} \text{ or } \text{sec } \theta = \frac{1}{\text{cos } \theta} \text{ or } \text{cos } \theta \cdot \text{sec } \theta = 1$$

$$\text{tan } \theta = \frac{1}{\text{cot } \theta} \text{ or } \text{cot } \theta = \frac{1}{\text{tan } \theta} \text{ or } \text{cot } \theta \cdot \text{tan } \theta = 1$$

By pythagoras theorem we have, $AC^2 = AB^2 + BC^2$

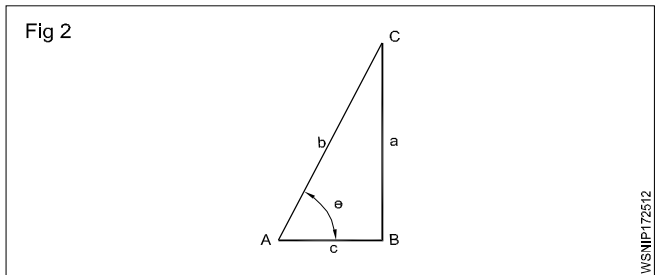

Dividing both sides of the equation by AC^2 , we have

$$\frac{AC^2}{AC^2} = \frac{AB^2}{AC^2} + \frac{BC^2}{AC^2}$$

$$= \left[\frac{AB}{AC} \right]^2 + \left[\frac{BC}{AC} \right]^2$$

$$1 = (\text{cos } \theta)^2 + (\text{sin } \theta)^2$$

$$\text{sin}^2 \theta + \text{cos}^2 \theta = 1$$

Sine, Cosine, Tangent, Cosec, Sec and Cotangent are the six trigonometrical ratios

$$\text{tan } \theta = \frac{\text{Sin } \theta}{\text{Cos } \theta} \text{ and } \text{sin}^2 \theta + \text{cos}^2 \theta = 1$$

$$\sin^2 \theta + \cos^2 \theta = 1$$

It can be transformed as

$$\sin^2 \theta = 1 - \cos^2 \theta$$

$$\sin \theta = \sqrt{1 - \cos^2 \theta}$$

$$\text{or } \cos^2 \theta = 1 - \sin^2 \theta$$

$$\cos \theta = \sqrt{1 - \sin^2 \theta}$$

$$\tan \theta = \frac{\sin \theta}{\cos \theta} = \frac{\sqrt{1 - \cos^2 \theta}}{\cos \theta}$$

$$\tan \theta = \frac{\sin \theta}{\sqrt{1 - \sin^2 \theta}}$$

We know $\sin^2 \theta + \cos^2 \theta = 1$

Dividing both sides by $\cos^2 \theta$.

$$\frac{\sin^2 \theta}{\cos^2 \theta} + \frac{\cos^2 \theta}{\cos^2 \theta} = \frac{1}{\cos^2 \theta}$$

$$\text{or } 1 + \tan^2 \theta = \sec^2 \theta$$

Using the same equation

$$\sin^2 \theta + \cos^2 \theta = 1.$$

Dividing both sides by $\sin^2 \theta$,

$$\frac{\sin^2 \theta}{\sin^2 \theta} + \frac{\cos^2 \theta}{\sin^2 \theta} = \frac{1}{\sin^2 \theta}$$

$$1 + \frac{\cos^2 \theta}{\sin^2 \theta} = \frac{1}{\sin^2 \theta}$$

$$1 + \cot^2 \theta = \operatorname{cosec}^2 \theta$$

$$1 + \tan^2 \theta = \sec^2 \theta$$

Trigonometrical Tables

Ratio	0°	30°	45°	60°	90°
sin θ	0	$\frac{1}{2}$	$\frac{1}{\sqrt{2}}$	$\frac{\sqrt{3}}{2}$	1
cos θ	1	$\frac{\sqrt{3}}{2}$	$\frac{1}{\sqrt{2}}$	$\frac{1}{2}$	0
tan θ	0	$\frac{1}{\sqrt{3}}$	1	$\sqrt{3}$	∞

When θ increases,

Sine value increases;

Cosine value decreases;

Tangent value increases to more than 1 when the angle is more than 45° ($\tan 60^\circ = 1.732$)

Sine of an angle = Cosine of its complementary angle

Cosine of an angle = Sine of its complementary angle

Examples

If $\sin 30^\circ = \frac{1}{2}$ find the value of $\sin 60^\circ$

By applying pythagores theorem

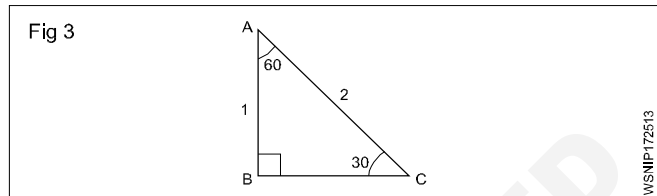

$$BC^2 = AC^2 - AB^2$$

$$BC^2 = 2^2 - 1^2$$

$$= 4 - 1$$

$$= 3$$

$$BC = \sqrt{3}$$

$$\sin 60^\circ = \frac{\sqrt{3}}{2}$$

$$\cos \theta = \frac{3}{5} \text{ Find the other trigonometrical ratios}$$

By applying pythagores theorem

$$AB^2 = AC^2 - BC^2$$

$$= 5^2 - 3^2 = 25 - 9$$

$$= 16$$

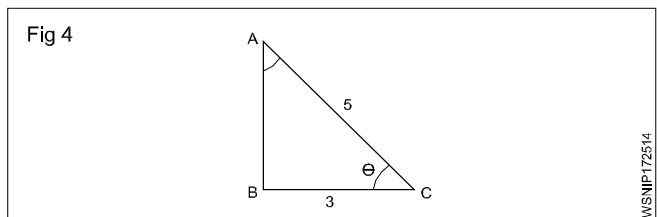

$$AB = \sqrt{16} = 4$$

$$\text{Now } \sin \theta = \frac{4}{5}$$

$$\tan \theta = \frac{4}{3}$$

$$\operatorname{Cosec} \theta = \frac{5}{4}$$

$$\sec \theta = \frac{5}{3}$$

$$\cot \theta = \frac{3}{4}$$

Signs of trigonometrical functions for angles more than 90°

Ratio	90 - θ	90 + θ	180 - θ	180 + θ	270 - θ	270 + θ	360 - θ	- θ
sin	cos	cos	sin	- sin	- cos	- cos	- sin	- sin
cos	sin	- sin	- cos	- cos	- sin	sin	cos	cos
tan	cot	- cot	- tan	tan	cot	- cot	- tan	- tan
cosec	sec	sec	cosec	- cosec	- sec	- sec	- cosec	- cosec
sec	cosec	- cosec	- sec	- sec	- cosec	cosec	sec	sec
cot	tan	- tan	- cot	cot	tan	- tan	- cot	- cot

Simplify :

$$\begin{aligned} \cot \theta + \tan (180+\theta) + \tan(90-\theta) + (\tan 360 - \theta) \\ = \cot \theta + \tan \theta - \cot \theta - \tan \theta \\ = 0 \end{aligned}$$

Simplify :

$$\begin{aligned} \frac{\cos (90+\theta) \sec (-\theta) \tan (180-\theta)}{\sec (360-\theta) \sin (180+\theta) \cos (90-\theta)} \\ = \frac{(-\sin \theta) \times (\sec \theta) \times (-\tan \theta)}{(\sec \theta) \times (-\sin \theta) \times (-\sin \theta)} \\ = \frac{\tan \theta}{\sin \theta} = \frac{1}{\cos \theta} = \sec \theta \end{aligned}$$

simplify:

$$\begin{aligned} \frac{\cos (90^{\circ}+\theta) \sec (-\theta) \tan (180^{\circ}-\theta)}{\sec (360^{\circ}-\theta) \sin (180^{\circ}+\theta) \cot (90^{\circ}-\theta)} \\ \cos (90^{\circ}+\theta) = -\sin \theta \\ \sec (-\theta) = \sec \theta \\ \tan (180^{\circ}-\theta) = -\tan \theta \end{aligned}$$

$$\sec (360^{\circ}-\theta) = \sec \theta$$

$$\sin (180^{\circ}+\theta) = -\sin \theta$$

$$\cot (90^{\circ}+\theta) = -\tan \theta$$

$$\begin{aligned} \frac{\cos (90^{\circ}+\theta) \sec (-\theta) \tan (180^{\circ}-\theta)}{\sec (360^{\circ}-\theta) \sin (180^{\circ}+\theta) \cot (90^{\circ}-\theta)} \\ = \frac{(-\sin \theta)(\sec \theta)(\tan \theta)}{(\sec \theta)(-\sin \theta)(-\tan \theta)} \\ = 1 \end{aligned}$$

Simplify:

$$\begin{aligned} \cot \theta + \tan (180^{\circ}+\theta) + \tan (90^{\circ}+\theta) + \tan (360^{\circ}-\theta) \\ \tan (180^{\circ}-\theta) = \tan \theta \\ \tan (90^{\circ}+\theta) = -\cot \theta \\ \tan (360^{\circ}-\theta) = -\tan \theta \\ \cot \theta + \tan (180^{\circ}+\theta) + \tan (90^{\circ}+\theta) + \tan (360^{\circ}-\theta) \\ \cot \theta + \tan \theta - \cot \theta - \tan \theta = 0 \end{aligned}$$

Assignment

- Given $\sin 30^{\circ} = 1/2$, find the value of $\tan 60^{\circ}$
- If $\cos \theta = 4/5$, find the other ratios
- If $\sin A = 3/5$, find $\cos \theta$, $\tan \theta$ & $\sec \theta$
- If $\tan \theta = 24/7$, find $\sin \theta$ and $\cos \theta$
- Find the value of $\cos \theta$ and $\tan \theta$, if $\sin \theta = 1/2$
- If $\cos \theta = 5/13$, find the value of $\tan \theta$
- If $\sin \theta = 1/2$, find the value of $\sin^2 \theta - \cos^2 \theta$

- What is the value of

$$\frac{\sin^2 30^{\circ}}{\cos^2 45^{\circ}} + \frac{\tan 45^{\circ}}{\sec 60^{\circ}} - \frac{\sin 60^{\circ}}{\cot 45^{\circ}} - \frac{\cos 30^{\circ}}{\sin 90^{\circ}}$$

Simplify :

- $\tan (90 + A) + (\tan 180 + A) \tan (90 + A)$
- $\frac{\cos (90 + \theta) \cdot \sec (-\theta) \cdot \tan (180 - \theta)}{\sec (360 + \theta) \cdot \sin (180 + \theta) \cdot \cot (90 + \theta)}$

Trigonometry - Trigonometrical tables

Use of trigonometrical tables (Ref: Sin, Cos & Tan Table)

Deg.	Minutes from 0 to 4						Mean difference				
	0'	6'	12'	18'	24'	54'	1'	2'	3'	4'	5'
0				.			.				
1				.			.				
2				.			.				
3				.			.				
.				.			.				
.				.			.				
.				.			.				
26	x	5			
.											
.											
.											
89											

Sine value for 26°–20'

Refer to Natural sine table.

Degrees column go up to 26° down

Minutes column 18' horizontal and under this note the value which is given as 0.4431.

Under mean difference for 2' in the same horizontal line 5 is given. Add this to the extreme right number noted for 26°–18'.

$$\text{Sine } 26^\circ - 20' = 0.4431 + .0005 = 0.4436$$

Cosine value for 43°–41'

Referring to the Natural cosines table for 43°–36' it is given as 0.7242 and the mean difference for 5' minutes is given as 10.

$$\begin{aligned} \cos 43^\circ - 41' &= \text{value for } \cos 43^\circ .36' \\ &\quad - \text{the value given for} \\ \text{mean difference of } 5' &= 0.7242 - 0.0010 \\ &= 0.7232 \end{aligned}$$

When reading sine value add the mean difference value. When reading cosine value subtract the mean difference value.

Arrangement

Values of trigonometrical ratios can be taken from mathematical tables.

The left hand vertical column consists of degrees.

The top horizontal column is arranged in minutes in steps of 6' from 0' to 54'. In the extreme right horizontal columns the mean differences are written in minutes from 1' to 5' in steps of 1' to account for angles with minutes between the interval of 6'.

- The values of cosine, cosecant and cotangent decrease when the value of the angle increases.
- For sine, secant and tangent, the value increases when the angle increases.
- The value of sine and cosine will never be more than 1.
- The value of secant and cosecant will never be less than 1.
- The value of Tan and Cot ranges from 0 to ∞.

EXAMPLE

From the tables obtain the cosine of 45° 20'.

$$\cos 45^\circ 18' = 0.7108$$

$$\text{mean difference for } 2' = 0.0004$$

$$\cos 45^\circ 20' = 0.7104$$

SINE TABLE

1 Sin 25° = 0.4226

2 Sin 17° 5'

$$\sin 17^\circ = 0.2924$$

$$\text{Difference } 5' = 14$$

$$\sin 17^\circ 5' = 0.2938 \quad \text{Ans}$$

3 sin 17° 45' 13"

$$\sin 17^\circ 46' = 0.3051$$

$$\sin 17^\circ 45' = 0.3048$$

$$\text{Difference } 1' = 0.0003$$

$$\begin{aligned}
 1'(\text{or}) 60'' &= 0.0003 \\
 13'' &= \frac{0.0003}{60} \times 13 \\
 &= \frac{0.0039}{60} \\
 &= \frac{0.00039}{6} \\
 &= 0.000065
 \end{aligned}$$

$$\begin{aligned}
 \sin 17^\circ 45' &= 0.3048 \\
 13'' &= 0.000065
 \end{aligned}$$

$$\sin 17^\circ 45' 13'' = 0.304865 \quad \text{Ans.}$$

4 sin 82° 14' 18"

$$\sin 82^\circ 15' = 0.9908$$

$$\sin 82^\circ 14' = 0.9908$$

$$\text{Difference } 1' = 0$$

$$1'(\text{or}) 60'' = 0$$

$$\sin 18'' = 0$$

$$\sin 82^\circ 14' = 0.9908$$

$$18'' = 0.0000$$

$$\sin 82^\circ 41' 18'' = 0.9908 \quad \text{Ans.}$$

Finding the corresponding angles when sine values are given:

1. Sin $\theta = 0.9925$

$$\theta = 83^\circ$$

2. Sin $\theta = 0.8791$

$$0.8788 = \sin 61^\circ 30'$$

$$0.0003 = 2'$$

$$0.8791 = \sin 61^\circ 32'$$

3. sin $\theta = 0.68015$

$$0.6794 = \sin 42^\circ 48'$$

$$0.0006 = 3'$$

$$0.6800 = \sin 42^\circ 51'$$

$$0.6803 = \sin 42^\circ 52'$$

$$\text{Difference } 0.0003 = 1' (\text{or}) 60''$$

$$\begin{aligned}
 0.00015 &= \frac{60}{0.0003} \times 0.00015 \\
 &= \frac{60 \times 15}{30} \\
 &= 30''
 \end{aligned}$$

$$0.6800 = \sin 42^\circ 51'$$

$$0.00015 = 30''$$

$$0.68015 = \sin 42^\circ 51' 30''$$

$$\theta = 42^\circ 51' 30''$$

Calculations involving tapers

D - Big diameter of the taper

d - small diameter of the taper

C - Taper Ratio - 1:x

Fig 1

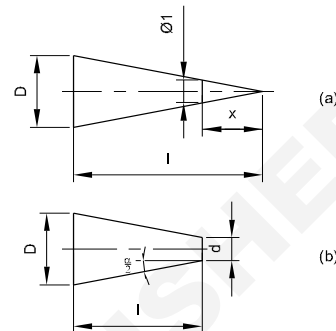

WSNIP172611

Fig 2

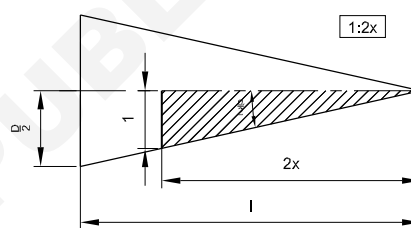

WSNIP172612

Fig 3

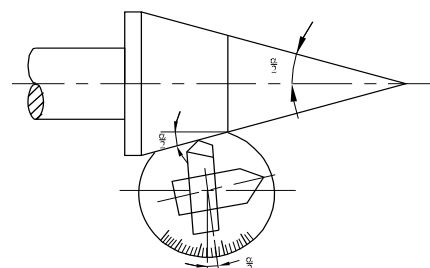

WSNIP172613

$\frac{C}{2}$ Ratio of inclination - 1:2 x

l - length of taper

a - included angle of taper

$\frac{\alpha}{2}$ - setting angle

Taper ratio = Ratio of inclination (for wedges).

Taper ratio

The ratio between the difference in diameter to the length of the taper is known as taper ratio. **D** is the difference in larger diameter shown in the sketch as the small diameter of taper is 0. Taper ratio is **D : l**. In the sectioned portion the difference in diameter is 1 and the length of taper is shown as **x**.

$C = D : d = 1 : x$ as per Fig 1 (a), $C = \frac{D-d}{l}$ as per Fig 1 (b)

Ratio of inclination

Taking half of the taper, $\frac{D}{2}$ is the difference in diameter for a taper length of l , if $d = 0$.

$$\therefore \frac{C}{2} = \frac{D}{2l} \quad \text{if the small diameter is 0}$$

$$\text{or } \frac{C}{2} = \frac{D-d}{2l}$$

1 Ratio of inclination = $\frac{1}{2}$ of the taper ratio.

Setting angle

One of the methods of turning taper is by swivelling the compound slide to an angle known as setting angle and feeding the tool at an angle to the axis of work.

$$\tan \frac{\alpha}{2} = \frac{C}{2} = \frac{D-d}{2l}$$

$$\tan \frac{\alpha}{2} = \frac{\text{taper ratio}}{2}$$

$$= \frac{\text{difference in diameter}}{2 \times \text{taper length}}$$

NOTE: $\frac{\alpha}{2}$ is the setting angle which is equal to half of the included angle of the taper.

Taper Ratio $C = 1 : x$ or $D : l$ or $(D-d) : l$

Ratio of inclination $\frac{C}{2} = 1 : 2x = \frac{D}{2} : l$ or $\left(\frac{D-d}{2}\right) : l$

Setting angle determination is by the formula

$$\tan \frac{\alpha}{2} = \frac{D-d}{2l} = \frac{C}{2}$$

Fig 4

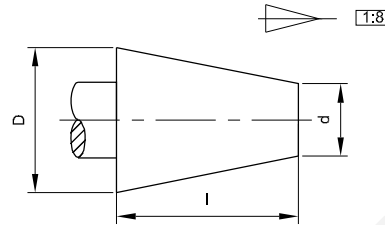

EXAMPLE

A pivot in the form of a frustum of a cone has a taper ratio 1:8. If the small diameter is 30 mm and length of taper is 80 mm, find its large diameter.

$$C = 1:8 = \frac{1}{8}$$

$$\therefore \frac{D-d}{l} = \frac{1}{8}$$

$$\therefore D-d = \frac{1}{8} \times 80 = 10 \text{ mm.}$$

$$D - 30 \text{ mm} = 10 \text{ mm}$$

$$D = 10 \text{ mm} + 30 \text{ mm} = 40 \text{ mm}$$

$$\text{Large diameter } D = 40 \text{ mm}$$

Cos Table

1 Cos 38°

$$\text{Cos } 38^\circ = 0.7880$$

2 Cos 83°12'

$$\text{Cos } 83^\circ 12' = 0.1184$$

3 Cos 26°40'

$$\text{Cos } 26^\circ 36' = 0.8942$$

$$4' = 5(-)$$

$$\text{Cos } 26^\circ 40' = 0.8937$$

4 Cos 31°20'

$$\text{Cos } 31^\circ 18' = 0.8545$$

$$2' = 3(-)$$

$$\text{Cos } 31^\circ 20' = 0.8542$$

Find the corresponding angles when cos values are given:

$$1 \quad \text{Cos } \theta = 0.5150$$

$$\theta = 59^\circ$$

$$2 \quad \text{Cos } \theta = 0.0192$$

$$\theta = 88^\circ 54'$$

$$3 \quad \text{Cos } \theta = 0.9682$$

$$0.9686 = \text{cos } 14^\circ 24'$$

$$(-) \quad 4 = 5'$$

$$0.9682 = \text{cos } 14^\circ 29'$$

$$\theta = 14^\circ 29'$$

4 **Cos θ = 0.8476**

0.8480 = cos 32° 0'

(-) 0.0003 = 2'

0.8477 = cos 32° 2'

0.8475 = cos 32° 3'

0.0002 = 1' (or) 60"
60

0.0001 = $\frac{\text{-----}}{0.0002} \times 0.0001$

60

= $\frac{\text{-----}}{2} \times 1$

= 30"

0.8477 = Cos 32° 2'

(-) 0.0001 = 30" (+)

0.8476 = Cos 32° 2' 30"

tan Table

1 tan 35° 37'

tan 35° 36' = 0.7159

1' = 0.0004

tan 35° 37' = 0.7163

2 tan 50° 5'

Tan 50° 0' = 1.1918

5' = 0.0036

Tan 50° 5' = 1.1954

Find the corresponding angles when tan values are given

1 tan θ = 0.3972

0.3959 = tan 21° 36'

0.0013 = 4'

0.3972 = tan 21° 40'

2 tan θ = 1.0065

1.0035 = tan 45° 6'

0.0030 = 5'

1.0065 = tan 45° 11'

Problems Related with Trigonometrical tables

1 A 250 mm Sine bar is used to measure an angle. If the difference in height is 5 cm, find the angle.

$$\sin \theta = \frac{\text{Opp.side}}{\text{Hyp.}} = \frac{h}{l}$$

$$= \frac{5 \text{ cm}}{250 \text{ mm}}$$

$$= \frac{50 \text{ mm}}{250 \text{ mm}}$$

= 0.2000

θ = 11° 32'

2 Find the height of the slip gauge if a Sine bar with plugs of 10" centre is set up to inspect a taper having an included angle of 9° 56".

$$\sin \theta = \frac{\text{Opp.side}}{\text{Hyp.}} = \frac{h}{l}$$

$$\sin 9^\circ 56'' = \frac{h}{10}$$

∴ h = 10 x sin 9° 56"

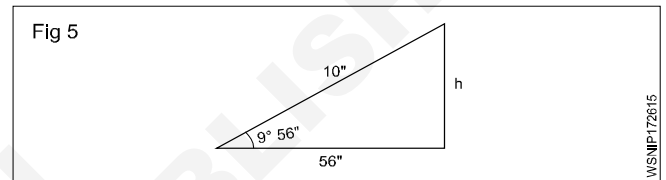

Sin 9° 0" = 0.1564

Sin 9° 1" = 0.1567

1' (or) 60" = 0.0003

$$56'' = \frac{0.0003}{60} \times 56$$

$$= \frac{0.0168}{60}$$

$$= \frac{0.00168}{6}$$

= 0.00028

sin 9° 0' 00" = 0.1564

56" = 0.00028

sin 9° 0' 56" = 0.15668

h = 10 x sin 9° 56"

= 10 x 0.15668

= 1.5668 cm

Height of slip gauge = 1.5668"

3 Find the angle which the ladder makes with the ground if the foot of a 4.5 m long ladder is placed at 1 m away from the wall.

In Right angled D

$$\cos C = \frac{BC}{AC}$$

$$\begin{aligned} \cos \theta &= \frac{1 \text{ m}}{4.5 \text{ m}} = 0.2222 \\ \cos &= 0.2222 \\ 0.2233 &= \cos 77^\circ 6' \\ (-) \quad 0.0011 &= \quad \quad \quad 4' (+) \\ \hline 0.2222 &= \cos 77^\circ 10' \\ \hline \theta &= 77^\circ 10' \end{aligned}$$

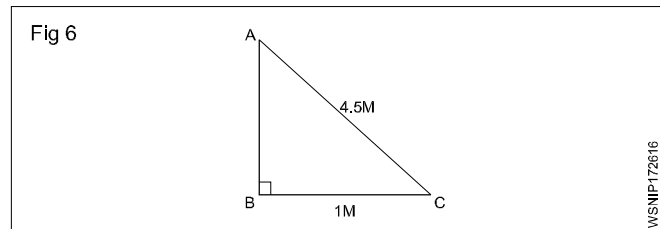

Assignment

I Find the values of the given angles

- 1 $\sin 65^\circ$
- 2 $\sin 42^\circ 23'$
- 3 $\sin 66^\circ 35' 32''$
- 4 $\sin 7^\circ 15' 41''$
- 5 $\sin 27^\circ 27''$
- 6 $\cos 26^\circ 40'$
- 7 $\cos 47^\circ 39'$
- 8 $\cos 79^\circ 31' 53''$
- 9 $\tan 28^\circ 45'$
- 10 $\tan 67^\circ 27' 36''$

II Find corresponding angles for given values

- 1 $\sin \theta = 0.3062$
- 2 $\sin \theta = 0.6002$
- 3 $\sin \theta = 0.22453$
- 4 $\sin \theta = 0.04802$
- 5 $\cos \theta = 0.6446$

- 6 $\cos \theta = 0.8926$
- 7 $\cos \theta = 0.11773$
- 8 $\cos \theta = 0.21646$
- 9 $\tan \theta = 0.3411$
- 10 $\tan \theta = 2.3868$

III

- 1 Calculate its base, if the slant height of a cone is 12.25 cm and the vertex angle is 110° .
- 2 A ladder 2.5 m long makes an angle of 60° with the ground. Find the height of the wall where the ladder touches the wall.
- 3 A sine bar of 200 mm is to be set at an angle of $15^\circ 15' 3''$. Select the slip gauge block to built up the required height.
- 4 In a right angled triangle ABC, $\angle C = 90^\circ$, If $AB = 50 \text{ mm}$ and $\angle B = 75^\circ$, Find the remaining sides.
- 5 Calculate the required length of the bar for this point if a centre point having an included angle of 60° is to be turned at the end of a 50 mm dia bar.

Natural Sines

°	0'	6'	12'	18'	24'	30'	36'	42'	48'	54'	1'	2'	3'	4'	5'
	0.0°	0.1°	0.2°	0.3°	0.4°	0.5°	0.6°	0.7°	0.8°	0.9°					
0	0.0000	0.0017	0.0035	0.0052	0.0070	0.0087	0.0105	0.0122	0.0140	0.0157	3	6	9	12	15
1	0.0175	0.0192	0.0209	0.0227	0.0244	0.0262	0.0279	0.0297	0.0314	0.0332	3	6	9	12	15
2	0.0349	0.0366	0.0384	0.0401	0.0419	0.0436	0.0454	0.0471	0.0488	0.0506	3	6	9	12	15
3	0.0523	0.0541	0.0558	0.0576	0.0593	0.0610	0.0628	0.0645	0.0663	0.0680	3	6	9	12	15
4	0.0698	0.0715	0.0732	0.0750	0.0767	0.0785	0.0802	0.0819	0.0837	0.0854	3	6	9	12	14
5	0.0872	0.0899	0.0906	0.0924	0.0941	0.0958	0.0976	0.0993	0.1011	0.1028	3	6	9	12	14
6	0.1045	0.1063	0.1080	0.1097	0.1115	0.1132	0.1149	0.1167	0.1184	0.1201	3	6	9	12	14
7	0.1219	0.1236	0.1253	0.1271	0.1288	0.1305	0.1323	0.1340	0.1357	0.1374	3	6	9	12	14
8	0.1392	0.1409	0.1426	0.1444	0.1461	0.1478	0.1495	0.1513	0.1530	0.1547	3	6	9	11	14
9	0.1564	0.1582	0.1599	0.1616	0.1633	0.1650	0.1668	0.1685	0.1702	0.1719	3	6	9	11	14
10	0.1736	0.1754	0.1771	0.1788	0.1805	0.1822	0.1840	0.1857	0.1874	0.1891	3	6	9	11	14
11	0.1908	0.1925	0.1942	0.1959	0.1977	0.1994	0.2011	0.2028	0.2045	0.2062	3	6	9	12	14
12	0.2079	0.2096	0.2113	0.2130	0.2147	0.2164	0.2181	0.2198	0.2215	0.2232	3	6	9	11	14
13	0.2250	0.2267	0.2284	0.2300	0.2317	0.2334	0.2351	0.2368	0.2385	0.2402	3	6	8	11	14
14	0.2419	0.2436	0.2453	0.2470	0.2487	0.2504	0.2521	0.2538	0.2554	0.2571	3	6	8	11	14
15	0.2558	0.2605	0.2622	0.2639	0.2656	0.2672	0.2689	0.2706	0.2723	0.2740	3	6	8	11	14
16	0.2756	0.2773	0.2790	0.2807	0.2823	0.2840	0.2857	0.2874	0.2890	0.2907	3	6	8	11	14
17	0.2924	0.2940	0.2957	0.2974	0.2990	0.3007	0.3024	0.3040	0.3057	0.3074	3	6	8	11	14
18	0.3090	0.3107	0.3123	0.3140	0.3156	0.3173	0.3190	0.3206	0.3223	0.3239	3	6	8	11	14
19	0.3256	0.3272	0.3289	0.3305	0.3322	0.3338	0.3355	0.3371	0.3387	0.3404	3	5	8	11	14
20	0.3420	0.3437	0.3453	0.3469	0.3486	0.3502	0.3518	0.3535	0.3551	0.3567	3	5	8	11	14
21	0.3584	0.3600	0.3616	0.3633	0.3649	0.3665	0.3681	0.3697	0.3714	0.3730	3	5	8	11	14
22	0.3746	0.3762	0.3778	0.3795	0.3811	0.3827	0.3843	0.3859	0.3875	0.3891	3	5	8	11	13
23	0.3907	0.3923	0.3939	0.3955	0.3971	0.3987	0.4003	0.4019	0.4035	0.4051	3	5	8	11	13
24	0.4067	0.4083	0.4099	0.4115	0.4131	0.4147	0.4163	0.4179	0.4195	0.4210	3	5	8	11	13
25	0.4226	0.4242	0.4258	0.4274	0.4289	0.4305	0.4321	0.4337	0.4352	0.4368	3	5	8	11	13
26	0.4384	0.4399	0.4415	0.4431	0.4446	0.4462	0.4478	0.4493	0.4509	0.4524	3	5	8	10	13
27	0.4540	0.4555	0.4571	0.4586	0.4602	0.4617	0.4633	0.4648	0.4664	0.4679	3	5	8	10	13
28	0.4695	0.4710	0.4726	0.4741	0.4756	0.4772	0.4787	0.4802	0.4818	0.4833	3	5	8	10	13
29	0.4848	0.4863	0.4879	0.4894	0.4909	0.4924	0.4939	0.4955	0.4970	0.4985	3	5	8	10	13
30	0.500	0.5015	0.5030	0.5045	0.5060	0.5075	0.5090	0.5105	0.5120	0.5135	3	5	8	10	13
31	0.5150	0.5165	0.5180	0.5195	0.5210	0.5225	0.5240	0.5255	0.5270	0.5284	2	5	7	10	12
32	0.5299	0.5314	0.5329	0.5344	0.5358	0.5373	0.5388	0.5402	0.5417	0.5432	2	5	7	10	12
33	0.5446	0.5461	0.5476	0.5490	0.5505	0.5519	0.5534	0.5548	0.5563	0.5577	2	5	7	10	12
34	0.5592	0.5606	0.5621	0.5635	0.5650	0.5664	0.5678	0.5693	0.5707	0.5721	2	5	7	10	12
35	0.5736	0.5750	0.5764	0.5779	0.5793	0.5807	0.5821	0.5835	0.5850	0.5864	2	5	7	9	12
36	0.5878	0.5892	0.5906	0.5920	0.5934	0.5948	0.5962	0.5976	0.5990	0.6004	2	5	7	9	12
37	0.6018	0.6032	0.6046	0.6060	0.6074	0.6088	0.6101	0.6115	0.6129	0.6143	2	5	7	9	12
38	0.6157	0.6170	0.6184	0.6198	0.6211	0.6225	0.6239	0.6252	0.6266	0.6280	2	5	7	9	11
39	0.6293	0.6307	0.6320	0.6334	0.6347	0.6361	0.6374	0.6388	0.6401	0.6414	2	4	7	9	11
40	0.6428	0.6441	0.6455	0.6468	0.6481	0.6494	0.6508	0.6521	0.6534	0.6547	2	4	7	9	11
41	0.6561	0.6574	0.6587	0.6600	0.6613	0.6626	0.6639	0.6652	0.6665	0.6678	2	4	7	9	11
42	0.6691	0.6704	0.6717	0.6730	0.6743	0.6756	0.6769	0.6782	0.6794	0.6807	2	4	6	9	11
43	0.6820	0.6833	0.6845	0.6858	0.6871	0.6884	0.6896	0.6909	0.6921	0.6934	2	4	6	8	11
44	0.6947	0.6959	0.6972	0.6984	0.6997	0.7009	0.7022	0.7034	0.7046	0.7059	2	4	6	8	10
45	0.7071	0.7083	0.7096	0.7108	0.7120	0.7133	0.7145	0.7157	0.7169	0.7181	2	4	6	8	10
46	0.7193	0.7206	0.7218	0.7230	0.7242	0.7254	0.7266	0.7278	0.7290	0.7302	2	4	6	8	10
47	0.7314	0.7325	0.7337	0.7349	0.7361	0.7373	0.7385	0.7396	0.7408	0.7420	2	4	6	8	10
48	0.7431	0.7443	0.7455	0.7466	0.7478	0.7490	0.7501	0.7513	0.7524	0.7536	2	4	6	8	10
49	0.7547	0.7558	0.7570	0.7581	0.7593	0.7604	0.7615	0.7627	0.7638	0.7649	2	4	6	8	9
50	0.7660	0.7672	0.7683	0.7694	0.7705	0.7716	0.7727	0.7738	0.7749	0.7760	2	4	6	7	9
51	0.7771	0.7782	0.7793	0.7804	0.7815	0.7826	0.7837	0.7848	0.7859	0.7869	2	4	5	7	9
52	0.7880	0.7891	0.7902	0.7912	0.7923	0.7934	0.7944	0.7955	0.7965	0.7976	2	4	5	7	9
53	0.7986	0.7997	0.8007	0.8018	0.8028	0.8039	0.8049	0.8059	0.8070	0.8080	2	3	5	7	9
54	0.8090	0.8100	0.8111	0.8121	0.8131	0.8141	0.8151	0.8161	0.8171	0.8181	2	3	5	7	8
55	0.8192	0.8202	0.8211	0.8221	0.8231	0.8241	0.8251	0.8261	0.8271	0.8281	2	3	5	7	8
56	0.8290	0.8300	0.8310	0.8320	0.8329	0.8339	0.8348	0.8358	0.8368	0.8377	2	3	5	6	8
57	0.8387	0.8396	0.8406	0.8415	0.8425	0.8434	0.8443	0.8453	0.8462	0.8471	2	3	5	6	8
58	0.8480	0.8490	0.8499	0.8508	0.8517	0.8526	0.8536	0.8545	0.8554	0.8563	2	3	5	6	8
59	0.8572	0.8581	0.8590	0.8599	0.8607	0.8616	0.8625	0.8634	0.8643	0.8652	1	3	4	6	7

Natural Sines

°	0'	6'	12'	18'	24'	30'	36'	42'	48'	54'	1'	2'	3'	4'	5'
	0.0°	0.1°	0.2°	0.3°	0.4°	0.5°	0.6°	0.7°	0.8°	0.9°					
60	0.8660	0.8669	0.8678	0.8686	0.8695	0.8704	0.8712	0.8721	0.8729	0.8738	1	3	4	6	7
61	0.8746	0.8755	0.8763	0.8771	0.8780	0.8788	0.8796	0.8805	0.8813	0.8821	1	3	4	6	7
62	0.8829	0.8838	0.8846	0.8854	0.8862	0.8870	0.8878	0.8886	0.8894	0.8902	1	3	4	5	7
63	0.8910	0.8918	0.8926	0.8934	0.8942	0.8949	0.8957	0.8965	0.8973	0.8980	1	3	4	5	6
64	0.8988	0.8996	0.9003	0.9011	0.9018	0.9026	0.9033	0.9041	0.9048	0.9056	1	3	4	5	6
65	0.9063	0.9070	0.9078	0.9085	0.9092	0.9100	0.9107	0.9114	0.9121	0.9128	1	2	4	5	6
66	0.9135	0.9143	0.9150	0.9157	0.9164	0.9171	0.9178	0.9184	0.9191	0.9198	1	2	3	5	6
67	0.9205	0.9212	0.9219	0.9225	0.9232	0.9239	0.9245	0.9252	0.9259	0.9265	1	2	3	4	6
68	0.9272	0.9278	0.9285	0.9291	0.9298	0.9304	0.9311	0.9317	0.9323	0.9330	1	2	3	4	5
69	0.9336	0.9342	0.9348	0.9354	0.9361	0.9367	0.9373	0.9379	0.9385	0.9391	1	2	3	4	5
70	0.9397	0.9403	0.9409	0.9415	0.9421	0.9426	0.9432	0.9438	0.9444	0.9449	1	2	3	4	5
71	0.9455	0.9461	0.9466	0.9472	0.9478	0.9483	0.9489	0.9494	0.9500	0.9505	1	2	3	4	5
72	0.9511	0.9516	0.9521	0.9527	0.9532	0.9537	0.9542	0.9548	0.9553	0.9558	1	2	3	3	4
73	0.9563	0.9568	0.9573	0.9578	0.9583	0.9588	0.9593	0.9598	0.9603	0.9608	1	2	2	3	4
74	0.9613	0.9617	0.9622	0.9627	0.9632	0.9636	0.9641	0.9646	0.9650	0.9655	1	2	2	3	4
75	0.9659	0.9664	0.9668	0.9673	0.9677	0.9681	0.9686	0.9690	0.9694	0.9699	1	1	2	3	4
76	0.9703	0.9707	0.9711	0.9715	0.9720	0.9724	0.9728	0.9732	0.9736	0.9740	1	1	2	3	3
77	0.9744	0.9748	0.9751	0.9755	0.9759	0.9763	0.9767	0.9770	0.9774	0.9778	1	1	2	2	3
78	0.9781	0.9785	0.9789	0.9792	0.9796	0.9799	0.9803	0.9806	0.9810	0.9813	1	1	2	2	3
79	0.9816	0.9820	0.9823	0.9826	0.9829	0.9833	0.9836	0.9839	0.9842	0.9845	1	1	2	2	3
80	0.9848	0.9851	0.9854	0.9857	0.9860	0.9863	0.9866	0.9869	0.9871	0.9874	0	1	1	2	2
81	0.9877	0.9880	0.9882	0.9885	0.9888	0.9890	0.9893	0.9895	0.9898	0.9900	0	1	1	2	2
82	0.9903	0.9905	0.9907	0.9910	0.9912	0.9914	0.9917	0.9919	0.9921	0.9923	0	1	1	1	2
83	0.9925	0.9928	0.9930	0.9932	0.9934	0.9936	0.9938	0.9940	0.9942	0.9943	0	1	1	1	2
84	0.9945	0.9947	0.9949	0.9951	0.9952	0.9954	0.9956	0.9957	0.9959	0.9960	0	1	1	1	1
85	0.9962	0.9963	0.9965	0.9966	0.9968	0.9969	0.9971	0.9972	0.9973	0.9974	0	0	1	1	1
86	0.9976	0.9977	0.9978	0.9979	0.9980	0.9981	0.9982	0.9983	0.9984	0.9985	0	0	1	1	1
87	0.9986	0.9987	0.9988	0.9989	0.9990	0.9990	0.9991	0.9992	0.9993	0.9993	0	0	0	1	1
88	0.9994	0.9995	0.9995	0.9996	0.9996	0.9997	0.9997	0.9997	0.9998	0.9998	0	0	0	0	0
89	0.9998	0.9999	0.9999	0.9999	0.9999	1.0000	1.0000	1.0000	1.0000	1.0000	0	0	0	0	0
90	1.0000														

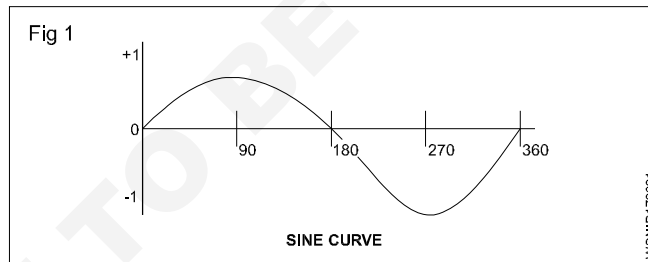

Quadrant	Angle	sin A =	Examples
First	0 to 90°	sin A	sin 34°38' = 0.5683
Second	90° to 180°	sin(180° - A)	sin 145°22' = sin(180° - 145° 22') = sin 34°38' = 0.5683
Third	180° to 270°	-sin(A - 180°)	sin 214°38' = -sin(214°38' - 180°) = -sin 34°38' = -0.5683
Fourth	270° to 360°	-sin(360° - A)	sin 325°22' = -sin(360° - 325°22') = -sin 34°38' = -0.5683

Natural Cosines

Numbers in different columns to be subtracted, not added

°	0' 0.0°	6' 0.1°	12' 0.2°	18' 0.3°	24' 0.4°	30' 0.5°	36' 0.6°	42' 0.7°	48' 0.8°	54' 0.9°	1'	2'	3'	4'	5'
0	1.0000	1.0000	1.0000	1.0000	1.0000	1.0000	0.9999	0.9999	0.9999	0.9999	0	0	0	0	0
1	0.9998	0.9998	0.9998	0.9997	0.9997	0.9997	0.9996	0.9996	0.9995	0.9995	0	0	0	0	0
2	0.9994	0.9993	0.9993	0.9992	0.9991	0.9991	0.9990	0.9989	0.9988	0.9987	0	0	0	1	1
3	0.9986	0.9985	0.9984	0.9983	0.9982	0.9981	0.9980	0.9979	0.9978	0.9977	0	0	1	1	1
4	0.9976	0.9974	0.9973	0.9972	0.9971	0.9969	0.9968	0.9966	0.9965	0.9963	0	0	1	1	1
5	0.9962	0.9960	0.9959	0.9957	0.9956	0.9954	0.9952	0.9951	0.9949	0.9947	0	1	1	1	1
6	0.9945	0.9943	0.9942	0.9940	0.9938	0.9936	0.9934	0.9932	0.9930	0.9928	0	1	1	1	2
7	0.9925	0.9923	0.9921	0.9919	0.9917	0.9914	0.9912	0.9910	0.9907	0.9905	0	1	1	1	2
8	0.9903	0.9900	0.9898	0.9895	0.9893	0.9890	0.9888	0.9885	0.9882	0.9880	0	1	1	2	2
9	0.9877	0.9874	0.9871	0.9869	0.9866	0.9863	0.9860	0.9857	0.9854	0.9851	0	1	1	2	2
10	0.9848	0.9845	0.9842	0.9839	0.9836	0.9833	0.9829	0.9826	0.9823	0.9820	1	1	2	2	3
11	0.9816	0.9813	0.9810	0.9806	0.9803	0.9799	0.9796	0.9792	0.9789	0.9785	1	1	2	2	3
12	0.9781	0.9778	0.9774	0.9770	0.9767	0.9763	0.9759	0.9755	0.9751	0.9748	1	1	2	2	3
13	0.9744	0.9740	0.9736	0.9732	0.9728	0.9724	0.9720	0.9715	0.9711	0.9707	1	1	2	3	3
14	0.9703	0.9699	0.9694	0.9690	0.9686	0.9681	0.9677	0.9673	0.9668	0.9664	1	1	2	3	4
15	0.9659	0.9655	0.9650	0.9646	0.9641	0.9636	0.9632	0.9627	0.9622	0.9617	1	2	2	3	4
16	0.9613	0.9608	0.9603	0.9598	0.9593	0.9588	0.9583	0.9578	0.9573	0.9568	1	2	2	3	4
17	0.9563	0.9558	0.9553	0.9548	0.9542	0.9537	0.9532	0.9527	0.9521	0.9516	1	2	3	3	4
18	0.9511	0.9505	0.9500	0.9494	0.9489	0.9483	0.9478	0.9472	0.9466	0.9461	1	2	3	4	5
19	0.9455	0.9449	0.9444	0.9438	0.9432	0.9426	0.9421	0.9415	0.9409	0.9403	1	2	3	4	5
20	0.9397	0.9391	0.9385	0.9379	0.9373	0.9367	0.9361	0.9354	0.9348	0.9342	1	2	3	4	5
21	0.9336	0.9330	0.9323	0.9317	0.9311	0.9304	0.9298	0.9291	0.9285	0.9278	1	2	3	4	5
22	0.9272	0.9265	0.9259	0.9252	0.9245	0.9239	0.9232	0.9225	0.9219	0.9212	1	2	3	4	6
23	0.9205	0.9198	0.9191	0.9184	0.9178	0.9171	0.9164	0.9157	0.9150	0.9143	1	2	3	5	6
24	0.9135	0.9128	0.9121	0.9114	0.9107	0.9100	0.9092	0.9085	0.9078	0.9070	1	2	4	5	6
25	0.9063	0.9056	0.9048	0.9041	0.9033	0.9026	0.9018	0.9011	0.9003	0.8996	1	3	4	5	6
26	0.8988	0.8980	0.8973	0.8965	0.8957	0.8949	0.8942	0.8934	0.8926	0.8918	1	3	4	5	6
27	0.8910	0.8902	0.8894	0.8886	0.8878	0.8870	0.8862	0.8854	0.8846	0.8838	1	3	4	5	7
28	0.8829	0.8821	0.8813	0.8805	0.8796	0.8788	0.8780	0.8771	0.8763	0.8755	1	3	4	6	7
29	0.8746	0.8738	0.8729	0.8721	0.8712	0.8704	0.8695	0.8686	0.8678	0.8669	1	3	4	6	7
30	0.8660	0.8652	0.8643	0.8634	0.8625	0.8616	0.8607	0.8599	0.8590	0.8581	1	3	4	6	7
31	0.8572	0.8563	0.8554	0.8545	0.8536	0.8526	0.8517	0.8508	0.8499	0.8490	2	3	5	6	8
32	0.8480	0.8471	0.8462	0.8453	0.8443	0.8434	0.8425	0.8415	0.8406	0.8396	2	3	5	6	8
33	0.8387	0.8377	0.8368	0.8358	0.8348	0.8339	0.8329	0.8320	0.8310	0.8300	2	3	5	6	8
34	0.8290	0.8281	0.8271	0.8261	0.8251	0.8241	0.8231	0.8221	0.8211	0.8202	2	3	5	7	8
35	0.8192	0.8181	0.8171	0.8161	0.8151	0.8141	0.8131	0.8121	0.8111	0.8100	2	3	5	7	8
36	0.8090	0.8080	0.8070	0.8059	0.8049	0.8039	0.8028	0.8018	0.8007	0.7997	2	3	5	7	9
37	0.7986	0.7976	0.7965	0.7955	0.7944	0.7934	0.7923	0.7912	0.7902	0.7891	2	4	5	7	9
38	0.7880	0.7869	0.7859	0.7848	0.7837	0.7826	0.7815	0.7804	0.7793	0.7782	2	4	5	7	9
39	0.7771	0.7760	0.7749	0.7738	0.7727	0.7716	0.7705	0.7694	0.7683	0.7672	2	4	6	7	9
40	0.7660	0.7649	0.7638	0.7627	0.7615	0.7604	0.7593	0.7581	0.7570	0.7559	2	4	6	8	9
41	0.7547	0.7536	0.7524	0.7513	0.7501	0.7490	0.7478	0.7466	0.7455	0.7443	2	4	6	8	10
42	0.7431	0.7420	0.7408	0.7396	0.7385	0.7373	0.7361	0.7349	0.7337	0.7325	2	4	6	8	10
43	0.7314	0.7302	0.7290	0.7278	0.7266	0.7254	0.7242	0.7230	0.7218	0.7206	2	4	6	8	10
44	0.7193	0.7181	0.7169	0.7157	0.7145	0.7133	0.7120	0.7108	0.7096	0.7083	2	4	6	8	10
45	0.7071	0.7059	0.7046	0.7034	0.7022	0.7009	0.6997	0.6984	0.6972	0.6959	2	4	6	8	10
46	0.6947	0.6934	0.6921	0.6909	0.6896	0.6884	0.6871	0.6858	0.6845	0.6833	2	4	6	8	11
47	0.6820	0.6807	0.6794	0.6782	0.6769	0.6756	0.6743	0.6730	0.6717	0.6704	2	4	6	9	11
48	0.6691	0.6678	0.6665	0.6652	0.6639	0.6626	0.6613	0.6600	0.6587	0.6574	2	4	7	9	11
49	0.6561	0.6547	0.6534	0.6521	0.6508	0.6494	0.6481	0.6468	0.6455	0.6441	2	4	7	9	11
50	0.6428	0.6414	0.6401	0.6388	0.6374	0.6361	0.6347	0.6334	0.6320	0.6307	2	4	7	9	11
51	0.6293	0.6280	0.6266	0.6252	0.6239	0.6225	0.6211	0.6198	0.6184	0.6170	2	5	7	9	11
52	0.6157	0.6143	0.6129	0.6115	0.6101	0.6088	0.6074	0.6060	0.6046	0.6032	2	5	7	9	12
53	0.6018	0.6004	0.5990	0.5976	0.5962	0.5948	0.5934	0.5920	0.5906	0.5892	2	5	7	9	12
54	0.5878	0.5864	0.5850	0.5835	0.5821	0.5807	0.5793	0.5779	0.5764	0.5750	2	5	7	9	12
55	0.5736	0.5721	0.5707	0.5693	0.5678	0.5664	0.5650	0.5635	0.5621	0.5606	2	5	7	10	12
56	0.5592	0.5577	0.5563	0.5548	0.5534	0.5519	0.5505	0.5490	0.5476	0.5461	2	5	7	10	12
57	0.5446	0.5432	0.5417	0.5402	0.5388	0.5373	0.5358	0.5344	0.5329	0.5314	2	5	7	10	12
58	0.5299	0.5284	0.5270	0.5255	0.5240	0.5225	0.5210	0.5195	0.5180	0.5165	2	5	7	10	12
59	0.5150	0.5135	0.5120	0.5105	0.5090	0.5075	0.5060	0.5045	0.5030	0.5015	3	5	8	10	13

Natural Cosines

Numbers in different columns to be subtracted, not added

°	0'	6'	12'	18'	24'	30'	36'	42'	48'	54'	1'	2'	3'	4'	5'
	0.0°	0.1°	0.2°	0.3°	0.4°	0.5°	0.6°	0.7°	0.8°	0.9°					
60	0.5000	0.4985	0.4970	0.4955	0.4939	0.4924	0.4909	0.4894	0.4879	0.4863	3	5	8	10	13
61	0.4848	0.4833	0.4818	0.4802	0.4787	0.4772	0.4756	0.4741	0.4726	0.4710	3	5	8	10	13
62	0.4695	0.4679	0.4664	0.4648	0.4633	0.4617	0.4602	0.4586	0.4571	0.4555	3	5	8	10	13
63	0.4540	0.4524	0.4509	0.4493	0.4478	0.4462	0.4446	0.4431	0.4415	0.4399	3	5	8	10	13
64	0.4384	0.4368	0.4352	0.4337	0.4321	0.4305	0.4289	0.4274	0.4258	0.4242	3	5	8	11	13
65	0.4226	0.4210	0.4195	0.4179	0.4163	0.4147	0.4131	0.4115	0.4099	0.4083	3	5	8	11	13
66	0.4067	0.4051	0.4035	0.4019	0.4003	0.3987	0.3971	0.3955	0.3939	0.3923	3	5	8	11	13
67	0.3907	0.3891	0.3875	0.3859	0.3843	0.3827	0.3811	0.3795	0.3778	0.3762	3	5	8	11	13
68	0.3746	0.3730	0.3714	0.3697	0.3681	0.3665	0.3649	0.3633	0.3616	0.3600	3	5	8	11	14
69	0.3584	0.3567	0.3551	0.3535	0.3518	0.3502	0.3486	0.3469	0.3453	0.3437	3	5	8	11	14
70	0.3420	0.3404	0.3387	0.3371	0.3355	0.3338	0.3322	0.3305	0.3289	0.3272	3	5	8	11	14
71	0.3256	0.3239	0.3223	0.3206	0.3190	0.3173	0.3156	0.3140	0.3123	0.3107	3	6	8	11	14
72	0.3090	0.3074	0.3057	0.3040	0.3024	0.3007	0.2990	0.2974	0.2957	0.2940	3	6	8	11	14
73	0.2924	0.2907	0.2890	0.2874	0.2857	0.2840	0.2823	0.2807	0.2790	0.2773	3	6	8	11	14
74	0.2756	0.2740	0.2723	0.2706	0.2689	0.2672	0.2656	0.2639	0.2622	0.2605	3	6	8	11	14
75	0.2588	0.2571	0.2554	0.2538	0.2521	0.2504	0.2487	0.2470	0.2453	0.2436	3	6	8	11	14
76	0.2419	0.2402	0.2385	0.2368	0.2351	0.2334	0.2317	0.2300	0.2284	0.2267	3	6	8	11	14
77	0.2250	0.2233	0.2215	0.2198	0.2181	0.2164	0.2147	0.2130	0.2113	0.2096	3	6	9	11	14
78	0.2079	0.2062	0.2045	0.2028	0.2011	0.1994	0.1977	0.1959	0.1942	0.1925	3	6	9	11	14
79	0.1908	0.1891	0.1874	0.1857	0.1840	0.1822	0.1805	0.1788	0.1771	0.1754	3	6	9	11	14
80	0.1736	0.1719	0.1702	0.1685	0.1668	0.1650	0.1633	0.1616	0.1599	0.1582	3	6	9	11	14
81	0.1564	0.1547	0.1530	0.1513	0.1495	0.1478	0.1461	0.1444	0.1426	0.1409	3	6	9	11	14
82	0.1392	0.1374	0.1357	0.1340	0.1323	0.1305	0.1288	0.1271	0.1253	0.1236	3	6	9	12	14
83	0.1219	0.1201	0.1184	0.1167	0.1149	0.1132	0.1115	0.1097	0.1080	0.1063	3	6	9	12	14
84	0.1045	0.1028	0.1011	0.0993	0.0976	0.0958	0.0941	0.0924	0.0906	0.0889	3	6	9	12	14
85	0.0872	0.0854	0.0837	0.0819	0.0802	0.0785	0.0767	0.0750	0.0732	0.0715	3	6	9	12	14
86	0.0698	0.0680	0.0663	0.0645	0.0628	0.0610	0.0593	0.0576	0.0558	0.0541	3	6	9	12	15
87	0.0523	0.0506	0.0488	0.0471	0.0454	0.0436	0.0419	0.0401	0.0384	0.0366	3	6	9	12	15
88	0.0349	0.0332	0.0314	0.0297	0.0279	0.0262	0.0244	0.0227	0.0209	0.0192	3	6	9	12	15
89	0.0175	0.0157	0.0140	0.0122	0.0105	0.0087	0.0070	0.0052	0.0035	0.0017	3	6	9	12	15
90	0.0000														

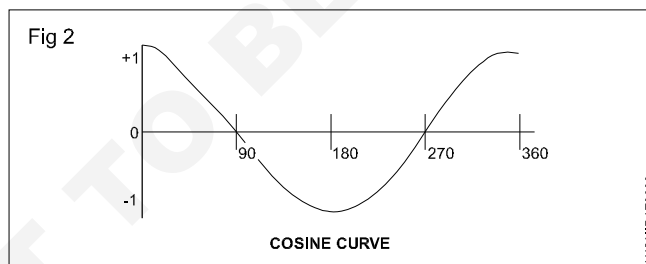

Quadrant	Angle	cos A =	Examples
First	0 to 90°	cos A	cos 33°26' = 0.8345
Second	90° to 180°	-cos(180° - A)	sin 146°34' = -cos(180° - 146°34') = -cos 33°26' = -0.8345
Third	180° to 270°	cos(A - 180°)	cos 213°26' = -cos(213°26' - 180°) = -cos 33°26' = -0.8345
Fourth	270° to 360°	cos(360° - A)	cos 326°34' = cos(360° - 326°34') = cos 33°26' = 0.8345

Natural Tangents

°	0'	6'	12'	18'	24'	30'	36'	42'	48'	54'	1'	2'	3'	4'	5'
	0.0°	0.1°	0.2°	0.3°	0.4°	0.5°	0.6°	0.7°	0.8°	0.9°					
0	0.0000	0.0017	0.0035	0.0052	0.0070	0.0087	0.0105	0.0122	0.0140	0.0157	3	6	9	12	15
1	0.0175	0.0192	0.0209	0.0227	0.0244	0.0262	0.0279	0.0297	0.0314	0.0332	3	6	9	12	15
2	0.0349	0.0367	0.0384	0.0402	0.0419	0.0437	0.0454	0.0472	0.0489	0.0507	3	6	9	12	15
3	0.0524	0.0542	0.0559	0.0577	0.0594	0.0612	0.0629	0.0647	0.0664	0.0682	3	6	9	12	15
4	0.0699	0.0717	0.0734	0.0752	0.0769	0.0787	0.0805	0.0822	0.0840	0.0857	3	6	9	12	15
5	0.0875	0.0892	0.0910	0.0928	0.0945	0.0963	0.0981	0.0998	0.1016	0.1033	3	6	9	12	15
6	0.1051	0.1069	0.1086	0.1104	0.1122	0.1139	0.1157	0.1175	0.1192	0.1210	3	6	9	12	15
7	0.1228	0.1246	0.1263	0.1281	0.1299	0.1317	0.1334	0.1352	0.1370	0.1388	3	6	9	12	15
8	0.1405	0.1423	0.1441	0.1459	0.1477	0.1495	0.1512	0.1530	0.1548	0.1566	3	6	9	12	15
9	0.1584	0.1602	0.1620	0.1638	0.1655	0.1673	0.1691	0.1709	0.1727	0.1745	3	6	9	12	15
10	0.1763	0.1781	0.1799	0.1817	0.1835	0.1853	0.1871	0.1890	0.1908	0.1926	3	6	9	12	15
11	0.1944	0.1962	0.1980	0.1998	0.2016	0.2035	0.2053	0.2071	0.2089	0.2107	3	6	9	12	15
12	0.2126	0.2144	0.2162	0.2180	0.2199	0.2217	0.2235	0.2254	0.2272	0.2290	3	6	9	12	15
13	0.2309	0.2327	0.2345	0.2364	0.2382	0.2401	0.2419	0.2438	0.2456	0.2475	3	6	9	12	15
14	0.2493	0.2512	0.2530	0.2549	0.2568	0.2586	0.2605	0.2623	0.2642	0.2661	3	6	9	12	16
15	0.2679	0.2698	0.2717	0.2736	0.2754	0.2773	0.2792	0.2811	0.2830	0.2849	3	6	9	13	16
16	0.2867	0.2886	0.2905	0.2924	0.2943	0.2962	0.2981	0.3000	0.3019	0.3038	3	6	9	13	16
17	0.3057	0.3076	0.3096	0.3115	0.3134	0.3153	0.3172	0.3191	0.3211	0.3230	3	6	10	13	16
18	0.3249	0.3269	0.3288	0.3307	0.3327	0.3346	0.3365	0.3385	0.3404	0.3424	3	6	10	13	16
19	0.3443	0.3463	0.3482	0.3502	0.3522	0.3541	0.3561	0.3581	0.3600	0.3620	3	7	10	13	16
20	0.3640	0.3659	0.3679	0.3699	0.3719	0.3739	0.3759	0.3779	0.3799	0.3819	3	7	10	13	17
21	0.3839	0.3859	0.3879	0.3899	0.3919	0.3939	0.3959	0.3979	0.4000	0.4020	3	7	10	13	17
22	0.4040	0.4061	0.4081	0.4101	0.4122	0.4142	0.4163	0.4183	0.4204	0.4224	3	7	10	14	17
23	0.4245	0.4265	0.4286	0.4307	0.4327	0.4348	0.4369	0.4390	0.4411	0.4431	3	7	10	14	17
24	0.4452	0.4473	0.4494	0.4515	0.4536	0.4557	0.4578	0.4599	0.4621	0.4642	4	7	11	14	18
25	0.4663	0.4684	0.4706	0.4727	0.4748	0.4770	0.4791	0.4813	0.4834	0.4856	4	7	11	14	18
26	0.4877	0.4899	0.4921	0.4942	0.4964	0.4986	0.5008	0.5029	0.5051	0.5073	4	7	11	15	18
27	0.5095	0.5117	0.5139	0.5161	0.5184	0.5206	0.5228	0.5250	0.5272	0.5295	4	7	11	15	18
28	0.5317	0.5340	0.5362	0.5384	0.5407	0.5430	0.5452	0.5475	0.5498	0.5520	4	8	11	15	19
29	0.5543	0.5566	0.5589	0.5612	0.5635	0.5658	0.5681	0.5704	0.5727	0.5750	4	8	12	15	19
30	0.5774	0.5797	0.5820	0.5844	0.5867	0.5890	0.5914	0.5938	0.5961	0.5985	4	8	12	16	20
31	0.6009	0.6032	0.6056	0.6080	0.6104	0.6128	0.6152	0.6176	0.6200	0.6224	4	8	12	16	20
32	0.6249	0.6273	0.6297	0.6322	0.6346	0.6371	0.6395	0.6420	0.6445	0.6469	4	8	12	16	20
33	0.6494	0.6519	0.6544	0.6569	0.6594	0.6619	0.6644	0.6669	0.6694	0.6720	4	8	13	17	21
34	0.6745	0.6771	0.6796	0.6822	0.6847	0.6873	0.6899	0.6924	0.6950	0.6976	4	9	13	17	21
35	0.7002	0.7028	0.7054	0.7080	0.7107	0.7133	0.7159	0.7186	0.7212	0.7239	4	9	13	17	22
36	0.7265	0.7292	0.7319	0.7346	0.7373	0.7400	0.7427	0.7454	0.7481	0.7508	5	9	14	18	23
37	0.7536	0.7563	0.7590	0.7618	0.7646	0.7673	0.7701	0.7729	0.7757	0.7785	5	9	14	18	23
38	0.7813	0.7841	0.7869	0.7898	0.7926	0.7954	0.7983	0.8012	0.8040	0.8069	5	9	14	19	24
39	0.8098	0.8127	0.8156	0.8185	0.8214	0.8243	0.8273	0.8302	0.8332	0.8361	5	10	15	20	24
40	0.8391	0.8421	0.8451	0.8481	0.8511	0.8541	0.8571	0.8601	0.8632	0.8662	5	10	15	20	25
41	0.8693	0.8724	0.8754	0.8785	0.8816	0.8847	0.8878	0.8910	0.8941	0.8972	5	10	16	21	26
42	0.9004	0.9036	0.9067	0.9099	0.9131	0.9163	0.9195	0.9228	0.9260	0.9293	5	11	16	21	27
43	0.9325	0.9358	0.9391	0.9424	0.9457	0.9490	0.9523	0.9556	0.9590	0.9623	6	11	17	22	28
44	0.9657	0.9691	0.9725	0.9759	0.9793	0.9827	0.9861	0.9896	0.9930	0.9965	6	11	17	23	28
45	1.0000	1.0035	1.0070	1.0105	1.0141	1.0176	1.0212	1.0247	1.0283	1.0319	6	12	18	24	30
46	1.0355	1.0392	1.0428	1.0464	1.0501	1.0538	1.0575	1.0612	1.0649	1.0686	6	12	18	25	31
47	1.0724	1.0761	1.0799	1.0837	1.0875	1.0913	1.0951	1.0990	1.1028	1.1067	6	13	19	25	32
48	1.1106	1.1145	1.1184	1.1224	1.1263	1.1303	1.1343	1.1383	1.1423	1.1463	7	13	20	27	33
49	1.1504	1.1544	1.1585	1.1626	1.1667	1.1708	1.1750	1.1792	1.1833	1.1875	7	14	21	28	34
50	1.1918	1.1960	1.2002	1.2045	1.2088	1.2131	1.2174	1.2218	1.2261	1.2305	7	14	22	29	36
51	1.2349	1.2393	1.2437	1.2482	1.2527	1.2572	1.2617	1.2662	1.2708	1.2753	8	15	23	30	38
52	1.2799	1.2846	1.2892	1.2938	1.2985	1.3032	1.3079	1.3127	1.3175	1.3222	8	16	24	31	39
53	1.3270	1.3319	1.3367	1.3416	1.3465	1.3514	1.3564	1.3613	1.3663	1.3713	8	16	25	33	41
54	1.3764	1.3814	1.3865	1.3916	1.3968	1.4019	1.4071	1.4124	1.4176	1.4229	9	17	26	34	43
55	1.4281	1.4335	1.4388	1.4442	1.4496	1.4550	1.4605	1.4659	1.4715	1.4770	9	18	27	36	45
56	1.4826	1.4882	1.4938	1.4994	1.5051	1.5108	1.5166	1.5224	1.5282	1.5340	10	19	29	38	48
57	1.5399	1.5458	1.5517	1.5577	1.5637	1.5697	1.5757	1.5818	1.5880	1.5941	10	20	30	40	50
58	1.6003	1.6066	1.6128	1.6191	1.6255	1.6319	1.6383	1.6447	1.6512	1.6577	11	21	32	43	53
59	1.6643	1.6709	1.6775	1.6842	1.6909	1.6977	1.7045	1.7113	1.7182	1.7251	11	23	34	45	56

Natural Tangents

°	0'	6'	12'	18'	24'	30'	36'	42'	48'	54'	1'	2'	3'	4'	5'
	0.0°	0.1°	0.2°	0.3°	0.4°	0.5°	0.6°	0.7°	0.8°	0.9°					
60	1.7321	1.7391	1.7461	1.7532	1.7603	1.7675	1.7747	1.7820	1.7893	1.7966	12	24	36	48	60
61	1.8040	1.8115	1.8190	1.8265	1.8341	1.8418	1.8495	1.8572	1.8650	1.8728	13	26	38	51	64
62	1.8807	1.8887	1.8967	1.9047	1.9128	1.9210	1.9292	1.9375	1.9458	1.9542	14	27	41	55	68
63	1.9626	1.9711	1.9797	1.9883	1.9970	2.0057	2.0145	2.0233	2.0323	2.0413	15	29	44	58	73
64	2.0503	2.0594	2.0686	2.0778	2.0872	2.0965	2.1060	2.1155	2.1251	2.1348	16	31	47	63	78
65	2.1445	2.1543	2.1642	2.1742	2.1842	2.1943	2.2045	2.2148	2.2251	2.2355	17	34	51	68	85
66	2.2460	2.2566	2.2673	2.2781	2.2889	2.2998	2.3109	2.3220	2.3332	2.3445	18	37	55	73	92
67	2.3559	2.3673	2.3789	2.3906	2.4023	2.4142	2.4262	2.4383	2.4504	2.4627	20	40	60	79	99
68	2.4751	2.4876	2.5002	2.5129	2.5257	2.5386	2.5517	2.5649	2.5782	2.5916	22	43	65	87	108
69	2.6051	2.6187	2.6325	2.6464	2.6605	2.6746	2.6889	2.7034	2.7179	2.7326	24	47	71	95	119
70	2.7475	2.7625	2.7776	2.7929	2.8083	2.8239	2.8397	2.8556	2.8716	2.8878	26	52	78	104	131
71	2.9042	2.9208	2.9375	2.9544	2.9714	2.9887	3.0061	3.0237	3.0415	3.0595	29	58	87	116	145
72	3.0777	3.0961	3.1146	3.1334	3.1524	3.1716	3.1910	3.2106	3.2305	3.2506	32	64	96	129	161
73	3.2709	3.2914	3.3122	3.3332	3.3544	3.3759	3.3977	3.4197	3.4420	3.4646	36	72	108	144	180
74	3.4874	3.5105	3.5339	3.5576	3.5816	3.6059	3.6305	3.6554	3.6806	3.7062	41	81	122	163	204
75	3.7321	3.7583	3.7848	3.8118	3.8391	3.8667	3.8947	3.9232	3.9520	3.9812	46	93	139	186	232
76	4.0108	4.0408	4.0713	4.1022	4.1335	4.1653	4.1976	4.2303	4.2635	4.2972	53	107	160	213	267
77	4.3315	4.3662	4.4015	4.4374	4.4737	4.5107	4.5483	4.5864	4.6252	4.6646					
78	4.7046	4.7453	4.7867	4.8288	4.8716	4.9152	4.9594	5.0045	5.0504	5.0970					
79	5.1446	5.1929	5.2422	5.2924	5.3435	5.3955	5.4486	5.5026	5.5578	5.6140					
80	5.6713	5.7297	5.7894	5.8502	5.9124	5.9758	6.0405	6.1066	6.1742	6.2432					
81	6.3138	6.3859	6.4596	6.5350	6.6122	6.6912	6.7720	6.8548	6.9395	7.0264					
82	7.1154	7.2066	7.3002	6.3962	7.4947	7.5958	7.6996	7.8062	7.9158	8.0285					
83	8.1443	8.2636	8.3863	8.5126	8.6427	8.7769	8.9152	9.0579	9.2052	9.3572					
84	9.5144	9.677	9.845	10.02	10.20	10.39	10.58	10.78	10.99	11.20					
85	11.43	11.66	11.91	12.16	12.43	12.71	13.00	13.30	13.62	13.95					
86	14.30	14.67	15.06	15.46	15.89	16.35	16.83	17.34	17.89	18.46					
87	19.08	19.74	20.45	21.20	22.02	22.90	23.86	24.90	26.03	27.27					
88	28.64	30.14	31.82	33.69	35.80	38.19	40.92	44.07	47.74	52.08					
89	57.29	63.66	71.62	81.85	95.49	114.6	143.2	191.0	286.5	573.0					
90	*														

DIFFERENCES
UNTRUSTWORTHY
HERE

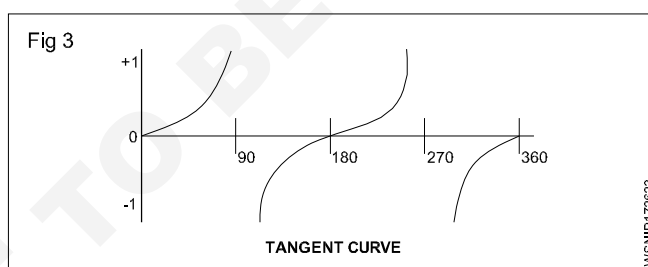

Quadrant	Angle	tan A =	Examples
First	0 to 90°	tan A	tan 56°17' = 1.4986
Second	90° to 180°	-tan(180° - A)	tan 123°43' = -tan(180° - 123° 43') = -tan 56°17' = -1.4986
Third	180° to 270°	tan(A - 180°)	tan 236°17' = tan(236°17' - 180°) = tan 56°17' = 1.4986
Fourth	270° to 360°	-tan(360° - A)	tan 303°43' = -tan(360° - 303°43') = -tan 56°17' = -1.4986